

Distributed By:
Green-Energy-Products.Com, LLC
305.251.9630 - 800.639.8796
info@green-energy-products.com



FREQUENTLY ASKED QUESTIONS

TENTH EDITION

January 2010

615 SOUTH STREET, GARDEN CITY, NY 11530

TEL: 800.526.2588/516-515-5000 or FAX: 800-526-2585/516-515-5050

168 BREA CANYON ROAD, CITY OF INDUSTRY, CA 91789

TEL: 877-810-6695/909-468-1848 or FAX: 800-987-9666/909-468-9958

www.waclighting.com

TABLE OF CONTENT – FREQUENTLY ASKED QUESTIONS
--

ENERGY EFFICIENT PENDANTS	4
MODERNISM™	5
QUICK CONNECT™ ELEMENTS	6
LEDME™ QUICK CONNECT™ PENDANTS	7
LEDME™ QUICK CONNECT™ PENDANT SOCKET SET	7
LEDME™ QUICK CONNECT™ FIXTURES	8
MONOPOINTS & MULTIPPOINTS CANOPIES	9
SOLORAIL™	10
DUORAIL™	13
FLEXRAIL1™	14
FLEXRAIL2™	16
BEAUTY SPOTS	17
COUNTER BALANCE CHANDELIERS	18
DECORATIVE WALL SCONCES	19
INVISILED™ TAPE	20
OUTDOOR INVISILED™ CLASSIC 24V	21
LOW VOLTAGE BUTTON LIGHTS/MINIATURE RECESSED	22
LEDME™ BUTTON LIGHTS	24
FLUORESCENT & XENON UNDERCABINET	25
LEDME™ LIGHT BARS	26
LINE VOLTAGE UNDERCABINET	27
LINEAR™ SYSTEM	28
120V TRACK SYSTEM	31
LARC	36
PRECISION SPOTS	37
LOW VOLTAGE TRACK FIXTURES	38
LEDME™ TRACK LUMINAIRES	40
COMPACT FLUORESCENT TRACK LUMINAIRES	41
METAL HALIDE (HID) TRACK LUMINAIRES	42
LINE VOLTAGE TRACK FIXTURES	43
LINE VOLTAGE PENDANTS	44
TRACK CURRENT LIMITER	45
MULTIPLE RECESSED SPOTS	46
LOW VOLTAGE RECESSED DOWNLIGHTING	47
METAL HALIDE DOWNLIGHTS	49
COMPACT FLUORESCENT DOWNLIGHTS	50
LINE VOLTAGE DOWNLIGHTS	51
LEDME™ DOWNLIGHTS	53

SURFACE MOUNT SPOTS.....54
DISPLAY LIGHTS.....55
LEDME™ SHOWCASE LIGHTS56
ELECTRONIC TRANSFORMERS.....57
MAGNETIC TRANSFORMERS60
CFL LAMPS.....61

ENERGY EFFICIENT PENDANTS – FREQUENTLY ASKED QUESTIONS

1. Are the WAC Lighting energy efficient pendants U.L. listed?

Yes, they are U.L. & C.U.L. listed.

2. What are the different ways I can order the pendant fixtures?

In 2009, WAC’s energy efficient pendants and Quick Connect™ pendants are ordered together with the matching socket set. The ordering matrix is as follows:

Mounting Type		Socket Set (see catalog p.3 - p.16)	Shade Model Number/finish	Adapter Finish	
				F1	F2
<i>Canopy mount</i>	PLD	F1 or F2	XXXXX	AB	BN
<i>Flexrail 1</i>	HM1	F1 or F2	XXXXX	DB	PT
<i>120V Track</i>	HTK (Halo) LTK (Lightolier) JTK (Juno)	F1 or F2	XXXXX	DB	BN

Example: LTK-F2-474WT/BN

You may also order pendant separately - example(*PLD-G + Shade Number*) : **PLD-G474WT**

The ordering matrix for energy efficient socket sets is as follows:

Mounting Type		Socket set F1	Socket Set F2	Finish Key: AB – Antique-Bronze BN - Brushed Nickel DB – Dark Bronze PT – Platinum
<i>Canopy mount</i>		PLD-MFL2-AB	PLD-MFL1-BN	
<i>Flexrail 1</i>		HM1-FL2-AB	HM1-FL1-PT	
<i>120V Track</i>	<i>H</i>	PLD-HTK-FL2-AB	PLD-HTK-FL1-AB	
	<i>L</i>	PLD-LTK-FL2-AB	PLD-LTK-FL1-AB	
	<i>J</i>	PLD-JTK-FL2-AB	PLD-JTK-FL1-AB	

3. Can I extend the socket set more than 8 feet?

Energy efficient socket sets are only available in one length - 96 inches from the factory. Contact your local WAC Lighting representative or the WAC factory for ordering information.

4. Can the pendant socket sets be field shortened? If so, which end of the cord do I shorten?

Cord length adjustment is easily accomplished on track models by unscrewing the bottom portion of the socket holder, and trimming the socket wire to the desired length from the socket side, monopoints may also be shortened at either end.

5. How can you mount a pendant light on a sloped ceiling?

The canopy or track fixture is installed as usual on the sloped ceiling. The cord makes the pendant hang straight.

6. Do you offer a “Hang-Straight” tube for the line voltage pendants ?

No. The tube accessory is not necessary for the line voltage pendants as the weight of the shade is sufficient to pull the cord straight.

7. What is included in the socket set?

The socket set includes the socket, a 96” 3 conductor cord, and a holding ring to secure the shade to the socket holder. (canopy or track adapter)

8. Can you use an incandescent lamp for energy efficient pendant series?

Yes, but only when you see an F4 socket set given as a choice.

9. Are they dimmable?

The compact fluorescent lamps are not dimmable, however, the incandescent lamps are dimmable with an incandescent dimmer.

MODERNISM™ ENERGY EFFICIENT LUMINAIRES – FREQUENTLY ASKED QUESTIONS

1. Are your Modernism Energy Efficient Fixtures U.L. listed?

Yes, they are U.L. & C.U.L. listed.

2. How do I order the Modernism fixture?

Please refer to p. 19 – p.22 of our current WAC Product catalogue.

3. Are they dimmable?

Please consult WAC Lighting for dimming options.

4. How long is the cord provided?

The cord is 96 inches for the WAC Pendants, which can be shortened in the field. The stem is 5 inches for a semi-flush mount, and it is not field adjustable.

5. Can I install Modernism™ Fixtures on a sloped ceiling?

The flush mount can be installed on a sloped ceiling. However for pendant and semi-flush mount style, it is not designed to be used on a sloped ceiling.

QUICK CONNECT™ ELEMENTS – FREQUENTLY ASKED QUESTIONS

1. Are all your Quick Connect™ elements U.L. listed?

Yes they are U.L. & C.U.L. listed.

2. What is a ‘Quick Connect™’ element?

“Elements” are low voltage fixtures or pendants that connect to a Quick Connect™ Adaptor (Jack). The adaptor then attaches to the rail or track to provide a simple connection for the elements. The Quick Connect™ feature allows the same elements to be used on multiple systems throughout an installation.

3. What systems do the ‘Quick Connect™’ elements work with?

The Quick Connect™ track luminaires and pendants work with the following systems;

120V TRACK	FLEXRAIL1™	SOLORAIL™	
LINEAR™	MONOPOINTS	MULTIPOINTS	FLEXRAIL2™

3. How do I order QC pendants?

You may order them as a complete fixture (includes shade, lamp and socket set , for example: QP530-GR/CH). The following table specifies the QC adaptor associated with your lighting system.

System type	Quick Connect™ Adapter Model	Description
Solorail™	LM-QADP	Attaches fixture to low voltage Solorail™.
Duorail™	LM2-QADP	Attaches fixture to low voltage Duorail™.
Flexrail1™	HM1-EN50	Includes integral transformer
Flexrail2™	HM-EN50	Includes integral transformer
Mono & Multipoints	None	Direct attachment to fixtures with integral transformers.
120V Track	EN-xQ50-AR	Includes integral transformer, x = specify track type(H, L or J).
Linear™ System	SADP	Attaches fixture to low volt track

Please specify the finish when you place order on the QC adapter.

4. In what standard lengths are Quick Connect™ track fixtures offered?

With the exception of the QF-196 which is 3 inches, they are all available in 3, 6, and 12 inch lengths.

5. Can QC fixtures be field cut?

No, the rigid tubes have an inner wire and can not be shortened.

6. Can the Quick Connect™ fixtures be extended longer than 12 inches?

Yes, they can be extended with the Q-X18, Q-X24, Q-X36, and Q-X48 extension rods.

7. Can I interchange the shade heads from series 184 and 195 series?

Yes, the fixtures with the coned shaped back, series 190, 194, and the 195 series are interchangeable with the 184 series.

8. Can these fixtures be used with a two circuit line voltage track?

Yes, you can use them on the J2 track (two circuit track). You will need an [EN-JQ50AR](#) Quick Connect™ adapter and a [JCLIP](#) in order to connect the Quick Connect™ fixture to the track.

9. Can the QF-185 accept an accessory lens?

Yes, the QF-185 fixture can accept an accessory lens. The lens compatibility matrix shown in page 193-194 of the current WAC catalog will provide you with detailed listing of lenses that can be used with Quick Connect™ fixtures.

10. Can Quick Connect™ fixtures be used on sloped ceilings?

When direct mounted, the fixtures have rigid stems that do not swivel from the top. However they can be mounted to various systems that can be suspended from a sloped ceiling, such as track, Flexrail1™, Solorail™, Duorail™, and linear systems.

LEDme™ Quick Connect™ Pendants - FREQUENTLY ASKED QUESTIONS

- 1. Are you LEDme™ Pendants UL Listed?**
Yes, they are UL & CUL listed. You can find listed products at www.ul.com.
- 2. What is the voltage/light output drop when using braid cord longer than 6 ft?**
There is minimal voltage drop when using a longer braid cord, however we don't recommend a cord longer than 15 feet.
- 3. Are LEDs replaceable like incandescent bulbs?**
LEDs are not replaceable as incandescent bulbs. However, we do sell LED modules for your pendants. The module itself is replaceable, when needed.
- 4. Can I use the LED pendant in Flexrail™, Standard track, or any other track and rail system?**
You may only use LEDme™ pendants on the Solorail™ and Duorail™ systems. You may not use the LED pendants on a line voltage system.
- 5. Can I use the LEDme™ Pendants in a Monopoint?**
LEDme™ Pendants can be ordered as a Monopoint.
- 6. How do I order a LEDme™ Pendants for each of the different systems?**
You will have to order a Quick Connect™ adaptor for the corresponding system. (Ie: LM-QADP, for Solorail™ system)
- 7. Can I use the LEDme™ Pendant in a Multipoint?**
No.
- 8. Can the LEDme™ Pendants be field shortened?**
Yes, LEDme™ Pendants can be field shortened.
- 9. Can I adjust the length of the LEDme™ Pendants after I have field shortened them?**
You cannot adjust the length of the cord once it has been shortened, however, if you are using the LED Monopoint, you can adjust the length upto 4 inches.
- 10. Can I use LED Pendants with an electronic transformer?**
You may only use an electronic transformer if it is 150 watts or higher. We recommend magnetic transformers.
- 11. What kind of dimmer can I use with LED Pendants?**
A Low voltage electronic dimmer.
- 12. What is the lifetime of a LEDme™ Pendant module?**
50,000 hours.

LEDme™ Quick Connect™ Pendant Socket Set - FREQUENTLY ASKED QUESTIONS

- 1. Are you LED Pendants UL Listed?**
Yes, they are UL & CUL listed. You can find listed products at www.ul.com.
- 2. What is the voltage/light output drop when using braid cord longer than 6 ft?**
There is minimal voltage drop when using a longer braid cord, however we don't recommend a cord longer than 15 feet.
- 3. What is the life of a LEDs in a Quick Connect™ Socket Set?**
30,000 hours. .
- 4. Are the LEDs in a Quick Connect™ Socket Set replaceable?**
No.
- 5. Can the LEDme™ Pendant Socket Set cords be field shortened?**
Yes, they can be field shortened.
- 6. Can I use LEDme™ Pendant Socket Set with existing WAC glass shades?**
You may use LED Pendant socket sets with existing WAC 500 Series Glass

LEDme™ Quick Connect™ FIXTURES – FREQUENTLY ASKED QUESTIONS

- 1. Are the LEDme™ Quick Connect™ Fixtures UL listed?**
Yes, all of our products are UL & CUL listed.
- 2. Are the LEDme™ QUICK CONNECT™ Fixtures dimmable?**
Yes, but only when being powered with a magnetic transformer, the dimmer used should be an ELECTRONIC low voltage dimmer.
- 3. Can the LEDme™ QUICK CONNECT™ Fixtures be mounted on a multipoint?**
No, because the electronic transformers contained within the multipoints would not be loaded to the minimum load requirements with a QUICK CONNECT™ Fixture.
- 4. Can I use the LEDme™ QUICK CONNECT™ Fixtures on the Solorail or Duorail system?**
Yes, however, you will need to meet the minimum load requirements of an electronic transformer. If you use a magnetic transformer, you will also be able to dim the fixtures with an ELECTRONIC low voltage dimmer. You will still need a QADP adapter to connect to Solorail (LM-QADP) or Duorail (LM2-QADP).
- 5. Can I use the LEDme™ QUICK CONNECT™ Fixtures with an existing 24V rail system?**
No, the QUICK CONNECT™ Fixtures and Pendants require a 12V system, not 24V.
- 6. Can you mix LEDme™ fixtures with other non-LED Fixtures and Pendants on Solorail or Duorail?**
Yes, with 12V only, you may mix the LED fixtures with other fixtures and pendants, be mindful of both the minimum and maximum loads of the transformer on the rail system.
- 7. Can I use the LEDme™ QUICK CONNECT™ Fixtures on the Flexrail1 or Flexrail2 system?**
No, the adapters connecting the QUICK CONNECT™ fixtures to Flexrail contain electronic transformers, you cannot attach LEDme™ QUICK CONNECT™ Fixtures to the Flexrail system.
- 8. What is the color temperature of the LEDme™ QUICK CONNECT™ Fixtures?**
The LEDme™ QUICK CONNECT™ Fixtures have a color temperature of 3000K.
- 9. What is the rated life of the LEDs in the QUICK CONNECT™ Fixtures?**
Our LED's in the QUICK CONNECT™ Fixture are rated for 30,000 hours of life. As with all of our products, there is a 5 year warranty on the LEDme™ QUICK CONNECT™ Fixtures.
- 10. Can the LED modules on the LEDme™ QUICK CONNECT™ fixtures be replaced?**
Yes, the QUICK CONNECT™ fixtures have a replaceable LED chip (module)

MONOPOINTS & MULTIPOINTS CANOPIES – FREQUENTLY ASKED QUESTIONS

1. Are your Monopoints and Multipoints U.L. listed?

Yes, they are U.L. and C.U.L. listed.

2. What fixtures can I use with the WAC Lighting Monopoints and Multipoints?

All of our Quick Connect™ fixtures (pendants or track fixtures) will work on the Monopoints and Multipoints.

3. Is a Quick Connect™ Adapter needed with the Monopoints or Multipoints?

Quick Connect™ elements mount directly to the Monopoints or Multipoints, a separate adapter is not needed.

4. What is the maximum wattage for a mono / multipoint?

50 watts per fixture.

5. Do any of your Monopoints / Multipoints allow the use of a remote transformer?

Our QMP-M1RN-TR and QMP-MI Monopoints allow the use of a remote low voltage transformer. The Multipoints all have integral electronic low voltage transformers.

6. Can I dim the Monopoint and Multipoints?

Yes, we recommend an electronic low voltage dimmer. Where a remote transformer is used, dimming can be accomplished by utilizing a dimmer to match transformer type (e.g. low voltage magnetic dimmer with a magnetic transformer).

7. Can the Monopoint and Multipoints be wall mounted or used on a sloped ceiling?

They are designed for flat ceiling use only.

8. Does the QMP-MI need a junction box? If it doesn't go on a junction box, how does it mount to a ceiling or surface?

It does not need a standard junction box. It comes with a wiring compartment that is attached with screws to the ceiling surface. The wiring compartment has a standard size knock-out on top and is 3" in height. (See diagram).

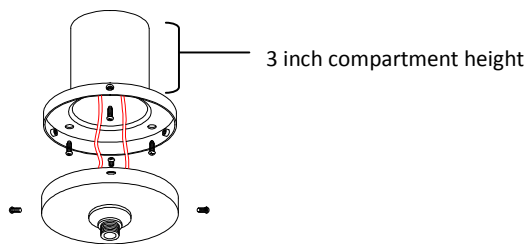

9. I am using a multi-point unit with some glass pendants in my kitchen. Can the pendant socket sets be field shortened?

Yes, socket sets are supplied in 6 foot lengths and may be cut to a desired length; follow the detailed instructions supplied with the socket.

10. One of the pendant fixtures on my 3 lights Multipoint does not light, should I try it in another Quick Connect™ fitting?

No, doing that can harm the other transformers. Remove the defective fixture immediately. Take one of the operating units and install it in the inoperative location. If it works there then the problem is in the fixture, and will most likely be caused by a faulty splice connection. Review the splice according to the instructions furnished. If the working pendant does not operate in that location then the transformer in that location may have shorted out due to the previous fixture. Using a QP Tester (Part #: QP-TESTER) can confirm whether or not the pendant is properly spliced. You can contact your distributor for a replacement or call our Lighting Specialists at 800.526.2588 for assistance.

SOLORAIL™ – SINGLE CIRCUIT MONORAIL™ – FREQUENTLY ASKED QUESTIONS

1. Is your low voltage Solorail™ system U.L. listed?

Yes, it is U.L. & C.U.L. listed.

2. What components do I need to build a complete Solorail™ system?

The basic components of a Solorail™ system are as follows:

- A. Transformer
- B. Power feed
- C. Rail & connectors
- D. Rail supports
- E. Fixtures / Pendants
- F. Quick Connect™ (Adaptors)

3. What is the capacity of Solorail™?

Mono rail is rated at 25 amps: this means a 12 volt system has a maximum capacity of 300 watts.

A 24 volt system has a maximum capacity of 600 watts.

4. What if I need more wattage?

You can use more than one power feed. Utilizing multiple power feeds between non-conductive I-connectors (I-DEC) gives you the appearance of one continuous run. Each section can then have up to 300W at 12V (or 600W at 24V).

5. How long can I make a Solorail™ system?

There are two considerations, capacity and voltage drop. In terms of capacity it can have as many power feeds as is necessary to support the wattage. In terms of voltage it is limited to the distance power can travel through the rail. See page 85 in the current WAC Lighting catalog for the corresponding voltage drop chart.

6. When powering from a remote transformer, what gauge of wire should I use between the transformer and the power feed?

A minimum 10 AWG wire should be used. Heavier gauge wire is needed if the transformer is not within close proximity to the power feed. See page 85 in the current WAC catalog for the corresponding voltage drop chart.

7. When I installed a dimmer on my Solorail™ System, the transformer started to buzz, what can I do about it?

Check that you have the correct dimmer switch for the type of transformer you are using (i.e. electronic low voltage dimmer with a electronic transformer, low voltage magnetic dimmer with a magnetic transformer). An integral de-buzzing coil is included with all of our surface mounted magnetic transformers. However an additional in-line de-buzzing coil (model# LM-DBC12XXX-XXX) between the dimmer and transformer is available to further reduce buzzing.

8. How does the Solorail™ attach to the ceiling?

The most common method is by rigid standoffs which are available in various lengths. We recommend 3 supports for an 8ft section of rail however a tightly curved rail may require more. We offer two variations of standoffs, one to fit on standard T-bar grid ceilings, and one to fit sloped ceilings. Additional cables are available 96" in length and are easily adjustable to shorter lengths.

9. Are the rigid standoffs field cut-able?

Yes the standoffs may be easily cut to custom lengths. The standard sizes range from 3" to 5 ¾" and additional rods are available up to 48".

10. Can I get longer standoffs?

Longer standoffs are accomplished by using a coupler to join two rods together. We offer 12", 24", 36" and 48" rods.

11. Can I field cut the Solorail™?

Yes, the monorail can be cut to any desired length. Additional end-caps may be purchased as needed.

12. Can we order rail in pre-curved sections?

No, Solorail™ is shipped in straight tubes and is easily bent in the field. For the cleanest and smoothest bend, work rail over a round object. Work to progressively smaller radiuses. Minimum radius is 12".

WAC also offers a bending machine (model number – **HM1-BM**) used to make smooth, consistent bends. For small radius bends, clamps onto work benches or flat surfaces up to 2" max

13. Can the pendant socket sets be field shortened?

Yes, socket sets are supplied in 6 foot lengths and may be cut to a desired length. Follow the instructions supplied with the socket set when field shortening.

14. Can sockets be ordered in longer than 6-foot lengths?

Generally, a six-foot drop is the maximum length. However certain socket sets are available in longer lengths but, not offered in our catalog because voltage drop reduces performance. Contact a Lighting Specialist for availability, 800.526.2588.

15. Your surface mount transformers seem heavy. Can it be attached to a standard fixture box?

They are designed to go on 4" junction boxes, but the box must be braced securely to the joists to support the weight of the transformer.

16. Do you have a kit that comes with all the basic components?

Yes, we have kits such as (**LM-SK-150E**) that include the basic system components. You may then select a complete element kit to finish the system or mix and match track heads and pendants to meet your individual needs. See page 128 to 132 of current WAC Lighting catalog for more ordering information.

17. What material is the rail made of?

Solorail™ is composed of two solid copper conductors separated by a plastic insulator.

18. How does power enter the Solorail™?

Through a power feed adapter. A power feed adapter is a two-piece assembly that clamps around the rail and energizes conductors. It is included in all surface mount transformers. Power feed canopies cover a junction box and are used with remote transformers. There are variations to mount from walls and a cable power wire for sloped ceilings.

19. How do I know whether to go with a 12 or 24 volt system?

This isn't an easy question to answer, please read the following scenario:

Project: You are the counter person at a lighting showroom. Your customer would like to use a rail system in their kitchen. They need 6 spotlights and three pendants over an island. It will be a 15-foot run. Where do you begin to plan out this system?

The thought process is essentially this: How many watts will all the fixtures total?

- a. How long of a run?
- b. Given the run length and wattage load, which power supply makes more sense - the 12 or the 24-volt?
- c. Given the maximum 300 watts for 12 volts and 600 watts for 24 volts, which power supply makes more sense?

For example, if all the fixtures in the above scenario are 50 watts, you'll be working with a total of 450 watts. A 12-volt system could be considered because the run is 15 feet. However, due to its maximum wattage of not more than 300 watts per run, this rail would have to be divided into two separate runs with two power feed sources.

In this scenario a 24-volt system would be more economical. The maximum wattage is now 600 watts and only one power feed and transformer are necessary. This will also give you a cleaner look. The homeowner has to be made aware that it's a 24-volt system and that replacement lamps are not as common as 12-volt lamps.

Lets assume you are going to do a 24-volt installation with a 600w remote magnetic transformer, this might be the project parts list:

1.	Six Quick Connect™ style spot lights	QF-194-CH
2.	Six shades	G116-CH
3.	Six MR16 lamps 24V, 50 W	MR16-EXN-24V-G
4.	Three Quick Connect™ pendant shades	QP524-TQ/CH
5.	Nine Quick Connect™ adapters	LM-QADP-CH
6.	Two 8 ft Solorails	LM-T8-CN
7.	One "I" connector	LM-I-CH
8.	One power feed canopy	LM-CPC-CH
9.	Approximately five ceiling standoffs	LM-X3-CH
10.	One remote 24V, 600W transformer	SRT-600M-24V

20. How do I lay out the Solorail™ and how do I install it on to the ceiling?

Lay out your Solorail™ on a workspace before you install it on the ceiling. Mark the location of standoff supports. If rail cannot be raised, use a plumb line or laser to mark location of standoff supports. For dry wall, drill holes and install ceiling anchors (supplied) through standoff bases then to ceiling.

21. What is a 'Quick Connect™' element?

"Elements" are a series of low voltage fixtures or pendants that connect to a Quick Connect™ Adaptor (Jack). The adaptor then attaches to the rail to provide a simple connection for the elements. The advantage of this system is the ability to easily use any of the over 300 low voltage Quick Connect™ elements on the Solorail™ system. The Quick Connect™ feature allows the same elements to be used on other systems, such as Flexrail1™, Duorail™, Monopoints and Multipoints, conventional 120V track, and the Linear track system.

22. Is your Quick Connect™ compatible with other systems?

Yes, our Quick Connect™ male end will fit into certain other manufacturers systems. Contact the factory or your local WAC Lighting supplier for compatibility information.

23. Can we install the Quick Connect™ fixtures while the rail is powered?

No, the system must be powered off before attaching any fixtures.

24. Can the Quick Connect™ fixtures be field cut?

The fixtures on rods have socket wires running through the centers and can not be cut.

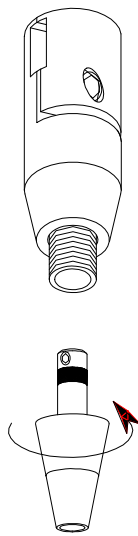

1. Is your low voltage Duorail™ system U.L. listed?

Yes, it is U.L. & C.U.L. listed.

2. What components do I need to build a complete Duorail™ system?

The basic components of a Duorail™ system are as follows:

- A. Transformer
- B. Power feed
- C. Rail / Connectors
- D. Rail supports
- E. Fixtures / Pendants
- F. Duorail™ Quick Connect™ Adaptors

3. What is the capacity of Duorail™?

Duorail™ is rated at 25 amps: this means a 12 volt system has a maximum capacity of 2 x 300 watts. A 24 volt system has a maximum capacity of 2 x 600 watts.

4. What if I need more wattage?

You can use more than one power feed. Utilizing multiple power feeds between non-conductive I-connectors (I-DEC) gives you the appearance of one continuous run. Each section can then have up to 2 x 300W at 12V (or 2 x 600W at 24V).

5. How long can I make a Duorail™ system?

There are two considerations, capacity and voltage drop. In terms of capacity it can have as many power feeds as is necessary to support the wattage. In terms of voltage it is limited to the distance power can travel through the rail.

See page 94 in the current WAC Lighting catalog for the corresponding voltage drop chart.

6. When powering from a remote transformer, what gauge of wire should I use between the transformer and the power feed?

A minimum 10 AWG wire should be used. Heavier gauge wire is needed if the transformer is not within close proximity to the power feed. See page 94 in the current WAC Lighting catalog for the corresponding voltage drop chart.

7. When I installed a dimmer on my Duorail™ System, the transformer started to buzz, what can I do about it?

Check that you have the correct dimmer switch for the type of transformer you are using (i.e. electronic low voltage dimmer with an electronic transformer, low voltage magnetic dimmer with a magnetic transformer). An integral de-buzzing coil is included with all of our surface mounted magnetic transformers. However an additional in-line de-buzzing coil (model# LM-DBC12XXXXXX) between the dimmer and transformer is available to further reduce buzzing.

8. How does the Duorail™ attach to the ceiling?

The most common method is by rigid standoffs which are available in various lengths. We recommend 3 supports for an 8ft section of rail however a tightly curved rail may require more. We offer two variations of standoffs, one to fit on standard T-bar grid ceilings, and one to fit sloped ceilings. Additional cables are available 96" in length and are easily adjustable to shorter lengths.

9. Are the rigid standoffs field cuttable?

Yes, the standoffs may be easily cut to custom lengths. The standard sizes range from 3" to 5 ¾" and additional rods are available up to 48".

10. Can I get longer standoffs?

Longer standoffs are accomplished by using a coupler to join two rods together.

11. Can I bend the Duorail™ in the field?

Yes, we recommend using our bending machine (HM1-BM).

12. Can I field cut the Duorail™?

Yes, the Duorail™ is field cuttable

13. Are all Quick Connect fixtures compatible with the Duorail™?

Yes, you may connect any of our Quick Connect pendants or fixtures to the Duorail™.

14. What is the difference between using a surface mount transformer and a remote transformer?

The surface mount transformers are mounted above the Duorail™, and can be seen on the surface of the ceiling. The remote transformer power feeds can be remoted further away, or in the ceiling, so they will not be seen.

FLEXRAIL1™– 120V MONORAIL SYSTEM – FREQUENTLY ASKED QUESTIONS

1. Is your Flexrail1™ system U.L. listed?

Yes, it is U.L. & C.U.L. listed.

2. What type of material makes up the rail?

Flexrail1™ is a semi rigid plastic extrusion encasing an aluminum core. The bus wires inside the rail are 12 AWG copper.

3. How do I feed power to the rail?

There are two different types of power feeds for the Flexrail1™. One is a rigid feed that matches up to our standard standoffs. The other is a flexible feed that would be used when the standoffs are cut to a non-standard length or in a sloped ceiling situation. They both cover a standard 4 inch octagon box and can be used anywhere along the Flexrail1™.

4. How does the rail mount to the ceiling?

It is mounted to fixed length standoffs that are available for flat, sloped, or suspended ceilings.

5. What are the basic components for a complete Flexrail1™ system?

1. The rail
2. Power feed, either the rigid stem or flexible cable type.
3. Rail supports (standoffs). Three per 8' section or every 42".
4. Quick Connect™ Pendants and fixtures
5. Flexrail1™ Quick Connect™ adapters

6. What is the capacity of Flexrail1™?

Flexrail1™ is rated at 20 amps, therefore the capacity of the system is 2400 watts. We recommend de-rating to 80% so that no circuit exceeds 1920 watts. De-rating is also advised when multiple connection points are being used.

7. How long can I make a Flexrail1™ system?

Since it uses 120 volts the rail is not limited by voltage drop issues. You will need to consider the maximum capacities in your system design.

8. Can I field cut the Flexrail1™?

Yes, the rail can be cut to a desired length with a chop saw or hacksaw. Additional end-caps may be purchased if needed.

9. Is the Flexrail1™ system dimmable?

Yes, it can be dimmed with a regular incandescent dimmer. If there is a Quick Connect™ element on the rail, an electronic low voltage dimmer is recommended.

10. You have a series of decorative fixtures called 'Quick Connect™', what does that mean?

"Quick Connect™" is a means of quickly installing low voltage fixtures similar to a plug in jack. Either a fixture or a pendant can connect to a rail mounted transformer (HM1-EN50). The advantage of this system is the ability to easily use any of the over 300 low voltage Quick Connect™ elements. In addition, this feature allows the same elements to be used on other Flexrail1™, Flexrail2™, track, and monopoint / multipoint, Solorail™, Duorail™ systems.

11. How many fixtures are available for the Flexrail1™ system?

The Flexrail1™ track system has 90 different track heads and glass pendants designed just to work with Flexrail1™. These units are the "HM1" series featured on our website and in our catalog. In addition, by using the Quick Connect™ transformer adaptor (HM1-EN50-XX) you can use any element from the Quick Connect™ family, that gives you an additional 300+ elements you can use with the system.

12. Can we install the Quick Connect™ fixtures while the rail is powered?

No, the system must be powered off before attaching any fixtures.

13. How is field bending accomplished?

We recommend using the bending tool for attaining smooth and consistent curves. The bending tool, HM1-BM, is available through your local distributor. Hand bending is possible, but smooth and consistent curves are more easily done with the HM-BM. The recommended minimum radius for bending is 23".

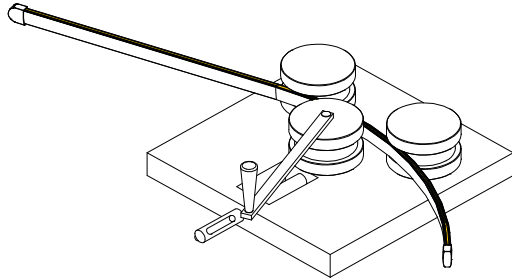

HM-BM bending tool

14. How many Power Feeds do I need for a 30' run of track?

The number of Power feeds required depends on the load, and not on the length. The track is able to accommodate 20 Amps, at 80% capacity, i.e. 16 Amps. That works out to 1920 watts maximum. If you are loading more than 1920 watt on the rail, you will need a second power feed.

15. Can I mount Flexrail1™ on the wall?

Flexrail1™ is not designed for wall mounting purposes.

FLEXRAIL2™ – TWO CIRCUIT 120V MONORAIL SYSTEM- FREQUENTLY ASKED QUESTIONS

1. Is your Flexrail2™ system U.L. listed?

Yes, they are U.L. and C.U.L. listed.

2. What type of material makes up the rail?

Flexrail2 is a semi rigid plastic extrusion encasing an aluminum core. The bus wires inside the rail are 12 AWG copper.

3. How do I feed power to the rail?

There are two different types of power feeds for the Flexrail2. One is a rigid feed that matches up to our standard standoffs. The other is a flexible feed that would be used when the standoffs are cut to a non-standard length or in a sloped ceiling situation. They both cover a standard 4 inch octagon box and can be used anywhere along the Flexrail2.

4. How does the rail mount to the ceiling?

It is mounted to fixed length standoffs that are available for flat, sloped, or suspended ceilings.

5. What are the basic components for a complete Flexrail2™ system?

- The rail.
- Power feed, either the rigid stem or flexible cable type.
- Rail supports (standoffs). Three per 8' section or every 42". More should be used when using heavy fixtures such as the compact fluorescent and metal halide track heads.
- Quick Connect™ Fixtures / Pendants
- Flexrail2™ Quick Connect™ adapters

6. What is the capacity of Flexrail2™?

Flexrail2™ is a two circuit system and each circuit is rated at 20 amps, therefore the capacity of the system is 2400w per circuit or 4800w total. We recommend de-rating to 80% so that each circuit does not exceed 1920W. De-rating is also advised when multiple connection points are being used.

7. How long can I make a Flexrail2™ system?

Since it uses 120 volts the rail is not limited by voltage drop issues. You will need to consider the maximum capacities in your system design.

8. How do the fixtures connect to each circuit?

The same fixtures are used for either circuit. To change circuit, the fixture connector needs to be rotated 180° on.

9. Can I field cut the Flexrail2™?

Yes, the rail can be cut to a desired length with a chop saw or hacksaw. Additional end-caps may be purchased if needed.

10. Is the Flexrail2 system dimmable?

Since the Flexrail2™ track has a shared neutral between the two circuits, only one circuit may be dimmed. The compact fluorescent and metal halide fixtures are not dimmable. See page 36 #11

11. How many fixtures are available for the Flexrail2 system?

The Flexrail2 track system has 90 different track heads and glass pendant designed just to work with Flexrail2. These units are the "HM" series featured on our website. In addition, by using the quick connect transformer adaptor (HM-EN50-XX) you can use any element from the Quick Connect™ family, that gives you an additional 300+ elements you can use with the system.

12. You have a series of decorative fixtures called 'Quick Connect™', what does that mean?

"Quick Connect™" is a means of quickly installing low voltage fixtures similar to a plug in jack. Either a fixture or a pendant can connect to a rail mounted transformer (HM-EN50). The advantage of this system is the ability to easily use any of the over 300 low voltage Quick Connect™ elements. In addition, this feature allows the same elements to be used on other rail, track, and monopoint/multipoint systems.

13. Can we install the quick connect fixtures while the rail is powered?

No, the system must be powered off before attaching any fixtures.

14. Can we order rail in pre-curved sections?

Yes, there are a series of 22" long sections in 30°, 45°, 60°, and 90° angles available. These sections are best used to make a track transition, but not to use in an entire layout.

15. How is field bending accomplished?

We do recommend using the bending tool for attaining smooth and consistent curves. The bending tool, HM1-BM, is available through your local distributor. Hand bending is possible, but using the bending tool is easier to create smooth and consistent curves. The recommended minimum radius for bending is 23".

BEAUTY SPOTS – FREQUENTLY ASKED QUESTIONS

1. Are your Beauty Spots U.L. listed?

Yes, they are U.L. & C.U.L. listed.

2. Are Beauty Spots considered a recessed fixture?

No, the electrical compartment is recessed into the ceiling. The decorative plate (canopy), lamp and crystal shade are on the surface of the ceiling.

3. Can insulation be in contact with the housing (IC Rated)?

The 'housing' on this beauty fixture is actually a wiring compartment. Therefore it may come in direct contact with insulation.

4. Are Beauty Spots low voltage or line voltage fixtures?

Beauty Spots are low voltage fixtures. 12volt or 24volt xenon lamps can be used, depending on the transformer voltage.

5. What holds the fixture in the ceiling?

Both the wiring compartment and canopy are held by flat "butterfly" spring clips.

1. What are the dimensions of the wiring compartment and canopy?

The wiring compartment is 2" wide by 2 7/8" tall. The canopy is 1/8" thick.

7. What size cutout do I need for the canopy?

It is a 2 3/8" cutout.

8. Can I install these lights in cabinetry or in a soffit?

Yes, beauty spots can be installed in wood, drywall, or even concrete.

9. Can I use the Beauty Spots in a bathroom?

Yes, the beauty spots are "damp listed" but can not be used directly over a tub or shower.

10. Can I install the canopy without the housing?

No, the housing is the wiring compartment and must be used in any installation.

11. How do the crystals fit onto the Beauty Spots?

The crystals are retained by a stainless steel tension spring. They snap on and off the base of the canopy without the use of any tools.

12. Can I change to a different color or style of crystal in the future?

Yes, refer to the current WAC Lighting product catalog or our website, www.waclighting.com, for our current crystal shade selection.

15. Are the Beauty Spots dimmable?

Yes, we recommend dimming with an electronic low voltage dimmer.

16. What is the best application for beauty spots?

Beauty spots are used as an accent light on ceilings. Many customers use beauty spots to create a unique pattern on their ceilings

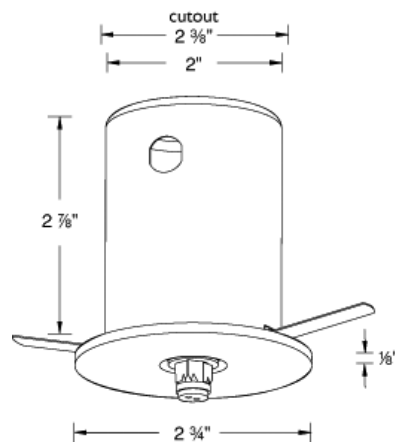

COUNTER BALANCE CHANDELIERS – FREQUENTLY ASKED QUESTIONS

1. Are your Adjustable Pendants U.L. listed?

Yes, they are U.L. & C.U.L. listed.

2. Do the Adjustable Pendants come with shades and lamps?

All the Adjustable Pendants come with xenon lamps and an integral electronic transformer. For the 5 and 7 light fixtures, white glass cylindrical shades are included.

The 1 and 3 light fixtures use shades from our G500 series and come with halogen lamps. These shades are ordered separately. See page 114 in the current WAC Lighting catalog for glass options.

3. Can I dim these pendants and chandeliers?

Yes, each is supplied with an integral electronic transformer. These transformers can be dimmed with electronic low voltage dimmers.

4. What is the drop length of the Counter Balance Adjustable Pendants?

The maximum length of the fixture drop is 72", and the minimum is 36". We have found this to accommodate most applications where the AP series adjustable pendants are used.

5. Your rectangular Adjustable Pendants are not wide enough to cover a ceiling junction box. How do I cover it?

Included with each rectangular Adjustable Pendant is an octagon junction box cover plate in a matching metal finish. If you do not like the color you can paint it to match the color of the ceiling.

6. How do I adjust the fixture height?

Each fixture has a counter weight that slides up and down. Some models come with spring loaded locks at the ends of the counter weight, depress the locks to release, then pull up and down to adjust the height. Care should be taken not to kink or twist the cables, as they are low voltage conductors as well as support cables.

7. Do the Adjustable Pendants have to be installed centered over the junction box?

Yes, the mounting plate permits only centered mounting.

DECORATIVE WALL SCONCES – FREQUENTLY ASKED QUESTIONS

1. Are your Wall Sconces U.L. listed?

Yes, they are U.L. and C.U.L. listed.

2. Do the Wall Sconces come with shades and lamps?

All low voltage wall sconces come with a shade, a 50W halogen bi-pin lamp and an integral electronic transformer.

All line voltage wall sconces come with a shade, and a 60W candelabra base incandescent lamp.

When ordering a WS-CFL32 and/or WS-INC60 back plate, the shade (G-WS404 / G-WS406) and lamp need to be purchased separately.

3. Can I substitute xenon lamps for the standard halogen type? What is the difference?

Yes, xenon lamps can be used if desired. Xenon lamps will give slightly less light than halogen, but offers almost twice the average lamp life.

4. Can I dim the low voltage Wall Sconces?

Yes, each is supplied with an integral 12V electronic transformer. It is recommended that these transformers be dimmed with an electronic low voltage dimmer.

5. Can I use a remote transformer with the Wall Sconces?

No, each sconce comes with an integral electronic low voltage transformer.

6. How do the Wall Sconces mount to the wall?

The Wall Sconces mount to a standard 4" fixture box.

7. Are Wall Sconces available in an ADA version?

Our WS-CFL32 and WS-INC60 back plate with shade as well as model numbers WS53, WS54, WS110, WS120, WS130 and WS230 comply with ADA federal regulation.

8. In what applications would I use these Wall Sconces?

The most common uses would be to illuminate a hallway, living area, bedroom, or lobby. They are also often used as companions to pendants using the same glass shade styles.

9. Can I use your Wall Sconces in a bathroom?

Yes, they are damp location listed, so they can be placed in a bathroom. To meet most building codes they should be located at least 3' from the shower stall.

INVISILED™ TAPE – FREQUENTLY ASKED QUESTIONS

1. Is INVISILED™ Tape Light U.L. listed?

Yes, they are U.L. and C.U.L. listed.

2. How can I tell the difference between the 12V and the 24V INVISILED™

The 12V INVISILED™ has 4-pin connectors, while the 24V has 5-pin.

3. Is INVISILED™ tape light dimmable?

The PALETTE and AURA models are dimmable through the LED-TC-CTR controller. Otherwise for our CLASSIC 12V and 24V models, we recommend using an Electronic Low Voltage (ELV) dimmer.

4. What is the maximum run for INVISILED™?

The maximum length of the 12V classic is a run of 25 feet per power supply. The maximum for 24V is 40 feet per power supply.

5. What is the minimum run for INVISILED™?

The minimum length run is 1 foot.

6. The longest joiner cable you sell is 72” what if I need to cover a distance greater than 72”?

The joiner cables may be interconnected in the same manner as the LED sections.

7. I need to create an angle other than 90°, what can I do?

We sell joiner cables as short as 3” (LED-TC-IC2), which can be angled as needed.

8. Can INVISILED™ be installed outdoors?

INVISILED™ is UL listed for damp locations, not wet.

9. Can INVISILED™ be field shortened?

Yes, keep in mind that the cut piece cannot be reused. 12V may be field cut every 1” and 24V CLASSIC can be field cut every 2”. PALETTE and AURA are field cuttable every 6”. We also offer 2” sections that can be used at the end of a run to reduce waste.

10. Where do I need to use track/ retrofit channel?

If the double sided tape will not adhere to the surface you need, you may use the retrofit channel (LED-T-RC), or the mounting clips (LED-T-CL) to mount the INVISILED™ to any surface. The tape is not designed to stick to porous materials, such as unfinished wood or brick.

11. How is the life expectancy calculated for LED products?

Unlike halogen calculations where the lamp life is rated at the point where 50% of the lamps fail, LEDs life expectancy is the point which the lamp is at 70% of its original output (brightness). All of our LED products are listed with a 50,000 hour life.

12. Can the INVISILED™ be walked on or stepped on?

No, the INVISILED™ is not designed to handle the force of being walked or stepped on.

INVISILED™ CLASSIC 24V OUTDOOR– FREQUENTLY ASKED QUESTIONS

1. Is Outdoor INVISILED™ tape light U.L. listed?

Yes, they are U.L. and C.U.L. wet location listed.

2. Is Outdoor INVISILED™ tape light dimmable?

No, it is not dimmable for the outdoor INVISILED™ tape light because it uses a DC power supply instead of a transformer.

3. What is the maximum run for outdoor INVISILED™?

The maximum run is 40 feet per power supply.

4. What is the minimum run for INVISILED™?

The minimum length run is 1 foot.

5. The longest joiner cable you sell is 120" (10 feet) what if I need to cover a distance greater than 120"?

The joiner cables may be interconnected in the same manner as the LED sections up to a maximum of 30'

6. I need to create an angle, what can I do?

We have X, Y connectors and joiner cable as short as 6" (LED-TO24-IC6), which can be angled as needed.

7. Can outdoor INVISILED™ tape light be field shortened?

Yes, it is field cuttable every 2". An end cap (LED-TO24-EC) need to be placed and seal with silicon to make water tight application. Keep in mind that once you cut the tape you terminate the run and it cannot be reconnected.

8. How is the life expectancy calculated for LED products?

Unlike halogen calculations where the lamp life is rated at the point where 50% of the lamps fail, LEDs life expectancy is the point which the lamp is at 70% of its original output (brightness). Most of our LED products are listed with a 50,000 hour life.

9. Can the outdoor INVISILED™ tape light be walked on or stepped on?

No, it is not designed to handle the force of being walked or stepped on.

10. Is the Outdoor INVISILED™ bendable?

Yes, it is bendable vertically. However, they cannot be bent horizontally. In order to do a horizontal turn, X, Y connectors or joiner cable can be used.

11. How do I decide what kind of mounting options I need?

We provide 4 kinds of mounting options. For use on flat surface only where there is no edge contact, such as small recesses or coves, retrofit channel (LED-TO24-CH1) can be used. For use on non-flat surfaces only where there is no edge contact, such as curved or irregular walls, LED-TO24-C1 can be used. For use on non-flat surfaces allowing for contact on one edge, such as wooden or concrete stairs, LED-TO24-C2 can be used. For use on non-flat surfaces allowing for contact on both edges, such as curved or irregular recesses or coves, LED-TO24-C3 can be used.

12. How far away should I put my power supply?

Due to a potential voltage drop issue, power supply should not be placed more than 30' from the first tape light.

13. Can I put the Outdoor INVISILED™ in the water?

Yes, tape sections are IP-68 rated for submersion up to one meter.

14. When joining separate pieces of Outdoor INVISILED™, will the light be evenly distributed?

Due to the special design of the tape light connector, there will be no dark spots on a straight run.

15. Can the Outdoor INVISILED™ power supply (EN-TO24100-RB2-T) be placed in water?

The power supply is UL listed for wet location. However, it cannot be submersed into water.

16. What is the suitable ambient temperature for the Outdoor INVISILED™?

The recommended ambient temperature for best performance between -4 to 122°F

17. What is the lumen output for the Outdoor INVISILED™?

For Amber color tape, it is 22 Lm/ft. For Blue color tape, it is 20 Lm/ft. For Green color tape, it is 60 Lm/ft. For Red color tape, it is 35 Lm/ft. For White color tape, it is 90 Lm/ft.

LOW VOLTAGE BUTTON LIGHTS/MINIATURE RECESSED – FREQUENTLY ASKED QUESTIONS

1. Are these fixtures U.L. listed?
Yes, they are U.L. & C.U.L. listed.

2. What are the main features of these miniature low voltage fixtures?

FEATURE	HR- 86	HR- 88	HR-LED85	HR-1135, 1136, 1137	HR-1138, 1139
Lamping	BP-20 Bi-Pin 12V 20W Xenon	JC-20 Bi-Pin 12V 20W Halogen	LED 12V 3W	MR11 12V 20W-35W	JC-20 Bi-Pin 12V 20W Halogen
Lamp Included	Yes	Yes	Yes	No	Yes
Transformer Required	Remote Class II	Remote Class II	LEDme™ Driver	Remote Class II	Remote Class II
Mounting Options	Surface or Recessed	Surface or Recessed	Surface or Recessed	Recessed	Recessed

3. In what types of applications would you recommend using these Low Voltage fixtures?
They are ideal for shelving, cabinets and displays.

4. Can any of these fixtures be mounted in a drywall ceiling?
No, they are designed for use as cabinet style lights.

5. Please explain the mounting options for the Button Lights.
Each button light comes with a shallow back cover or “housing”. When installing a recessed into cabinets, you will not need the back cover. The cutout hole size is 2-3/8" (a pop-out template is included). If installed as a surface mounted fixture, you will need the decorative back cover.

6. What power supply can I use with these fixtures?
All of the LOW VOLTAGE BUTTON / MINIATURE RECESSED units are UL listed as requiring a Class II transformer. We offer a plug in or a hard wired model. HR-LED85 requires a LED driver.

7. What is a Class II transformer?
A Class II transformer is inherently limited to not more than 60 watts. It is a low energy device and considered intrinsically safe. Secondary wiring from a Class II transformer does not require conduit and clamp wiring techniques.

8. Can I order a frosted lens for the Button Lights?
Yes, LENS-45-FR.

9. Can I use a UV lens with the Button Lights?
No, our UV lenses are only available in the standard MR16 and MR11 sizes.

10. What is the length of the socket lead wire that comes with the Button Lights?
The length of the lead wire is 72". It may be spliced to additional wire for longer length. However heavier gauge wires should be used to avoid voltage drop (see table from question 15).

11. How many Button Light fixtures are required for a 6’ under cabinet run?
Generally, from a 24" height, a Button Light (or any 20W mini fixture) will provide sufficient light for 20" – 24" of space. So a 6’ run will require 3 fixtures.

12. Do I need to order a housing (can) miniature recessed lights?

No, they each have a built-in housing as part of the fixture.

Are the HR-1138 and HR-1139 available with a clear glass cover?

No, just frosted.

13. In a low voltage situation (12V) like a motor home or a boat, would I require a transformer for my fixtures?

Most RV's and boats operate under 12V. Transformers are not necessary.

14. I am concerned with a voltage drop in my application. Do you have any guidelines on the subject?

To minimize voltage drop or reduced light output, the transformer should be located as close to the fixture as possible. A drop of up to 5% is generally acceptable. The chart below details a guideline to keep the drop below 5%.

LAMP WATTAGE

WIRE SIZE	35W	50W	75W
18 gauge	8'	8'	6'
16 gauge	12'	12'	10'
14 gauge	16'	16'	14'
12 gauge	20'	20'	18'

LEDme™ BUTTON LIGHTS – FREQUENTLY ASKED QUESTIONS

1. Why does the LEDme™ Button Light get warm?

The LEDs do not project any heat downward, however, the metal housing acts as a heat sink, therefore it gets warm.

2. Are the LEDme™ button lights dimmable?

No, Currently LEDme™ button lights are not dimmable.

3. How is the life expectancy calculated for LED products?

Unlike halogen calculations where the lamp life is rated at the point where 50% of the lamps fail, LEDs life expectancy is the point which the lamp is at 70% of its original output (brightness). All of our LED products are listed with a 50,000 hour life.

4. Can the LEDme™ button lights be wired in series?

Yes, see diagram below

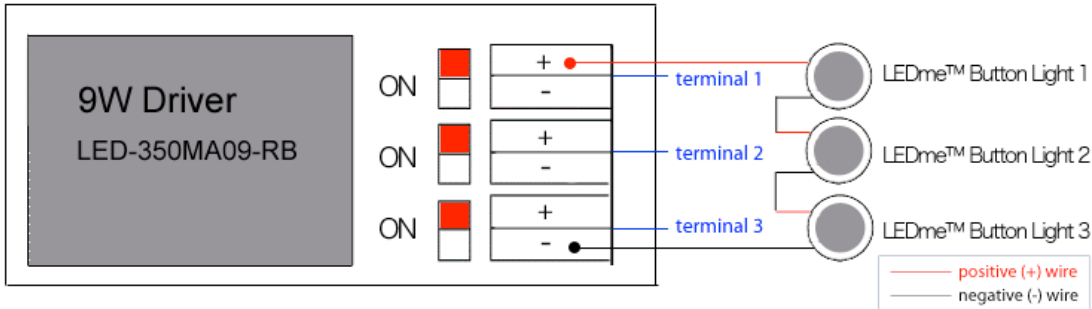

Note: A minimum of two Button Lights are required to wire in series. The positive wire needs to be connected to the positive port on terminal 1, the negative wire needs to be connected to the negative port on terminal 3

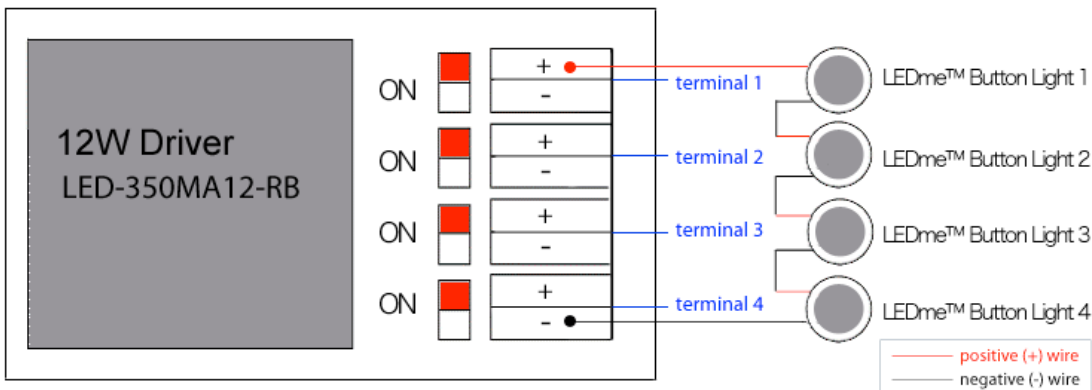

Note: A minimum of two Button Lights are required to wire in series. The positive wire needs to be connected to the positive port on terminal 1, the negative wire needs to be connected to the negative port on terminal 4

*However, the dimmable version cannot be wired in series.

5. Are the LEDme™ button lights the same size as the other button lights offered?

The LEDme™ button lights are slightly smaller than the xenon/halogen button lights we offer. However, there is a housing to adapt the larger opening to fit the smaller LEDme™ button light. (HR-LED-COV-XX) (XX refers to the finish of the housing you are looking for: BK, BN, CB, CH, DB or WT)

6. Can the LED module be switched out, or does the entire unit need to be replaced if the LEDs fail or burn out on the LEDme™ button lights?

Yes, you can change out the module (model number: RM3X1-30-HR) without soldering.

FLUORESCENT & XENON UNDERCABINET (LIGHT BARS) – FREQUENTLY ASKED QUESTIONS

1. Are the Xenon and Fluorescent under cabinet fixtures UL listed?

Yes, they are U.L. & C.U.L. listed.

2. Where and how many knockouts are on the Xenon and Fluorescent units.

The number and position varies with each fixture. There are knockout locations on both the back and sides of the undercabinet units. For more specific information refer to the product spec sheets available on our website, www.waclighting.com, or by contacting our WAC Lighting Specialist at 800.526.2588.

3. Can I connect several of these fixtures in a row? What is the limit?

Yes, you can connect fixtures totaling up to 700 watts. The fixtures are connected together by using the optional inter-connect cables or end to end with the use of "I" connector.

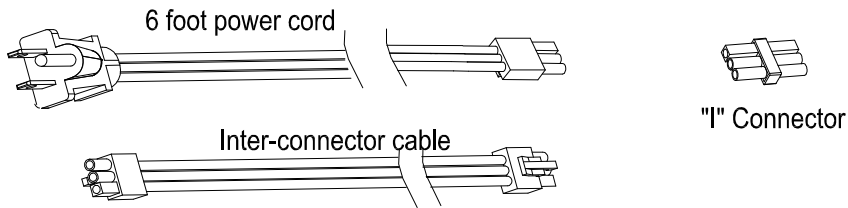

4. Can the Xenon lamps be changed to Halogen lamps?

Yes, they are interchangeable.

5. If one of the lamps goes out on the BA-X unit what happens to the rest of the lamps?

If one lamp goes out the remaining lamps will stay illuminated.

6. How do you change the lamps on the undercabinet Light Bar?

You may review the installation instructions available at our website, www.waclighting.com, or by contacting our WAC Lighting Specialist at 800.526.2588.

7. Can I order an under cabinet fluorescent light bar with a dimming ballast?

No, they are only available with standard electronic high efficiency fluorescent ballasts.

LEDme™ LIGHT BARS – FREQUENTLY ASKED QUESTIONS

1. How is the life expectancy calculated for LED products?

Unlike halogen calculations where the lamp life is rated at the point where 50% of the lamps fail, LEDs life expectancy is the point which the lamp is at 70% of its original output (brightness). All of our LED products are listed with a 50,000 hour life.

2. Are the LEDme™ light bars inter-connectable?

Yes, as of January 2010, the light bars are inter-connectable.

3. Do your LEDme™ light bars contain a high-low-off switch?

No, WAC LEDme™ light bars are not dimmable, therefore the switches are only on-off.

LINE VOLTAGE UNDERCABINET (LIGHT BARS) – FREQUENTLY ASKED QUESTIONS

1. Are the BA-LIX Line Voltage Light Bars U.L. listed?

Yes, they are U.L. & C.U.L. listed.

2. What is the lamp requirement of the Line Voltage Light Bars?

They use G8 bi-pin 120 volt 25 watt lamps.

Model	Voltage	Lamps	Wattage	Length
BA-LIX-1	120V	1 x 25W	25W	6"
BA-LIX-2	120V	2 x 25W	50W	12"
BA-LIX-3	120V	3 x 25W	75W	18"
BA-LIX-4	120V	4 x 25W	100W	24"
BA-LIX-6	120V	6 x 25W	150W	36"
BA-BX-1	120V	1 x 25W	25W	7"
BA-BX-2	120V	2 x 25W	50W	12"
BA-BX-3	120V	3 x 25W	75W	18"
BA-BX-4	120V	4 x 25W	100W	24"

3. For direct wiring, does the Line Voltage Light Bar come with knock-outs?

Yes, they also come with integral quick connect adaptors.

4. How is chain wiring of fixtures accomplished?

The fixture is supplied with sufficient internal wire to reach any of the knock out locations. This is high temperature wire, so do not run other wires through the fixture. However external wires may enter the fixture up to an 1 ½" so that wire nut connections can be made.

5. How many fixtures can be wired together?

Fixtures combination may be wired together up to 700watts

7. Can the BA-LIX be dimmed?

Yes, they have a built-in Hi-Lo switch. When using an additional wall dimmer (a regular incandescent) be sure to leave the Hi-Lo switch in the high setting.

8. Can I use clear lenses instead of the frosted lenses supplied with the Light Bars?

Yes, you may purchase the LENS-BAL-CL lens to replace the supplied frosted lens. They are fitted with the frosted lens to reduce glare.

9. Can these fixtures be installed in a damp location?

Yes, they are suitable for damp locations, above a sink for example, but not wet locations.

10. Can the light bars be installed above a stove or fire place?

No.

LINEAR™ SYSTEM – FREQUENTLY ASKED QUESTIONS

1. Is your LINEAR™ System U.L. listed?

Yes, it is U.L. & C.U.L. listed.

2. What material is your LINEAR™ track made of? Can this type of track be cut?

The track is made of polycarbonate. Yes, the linear track may be field-shortened with chop saw/ hacksaw

3. Is the LINEAR™ System low or line voltage?

It is low voltage. It requires the use of a transformer to power the track.

4. What type of transformers can I use with the low voltage LINEAR™ System track?

We have two types of transformers - electronic and magnetic. The SST-60E (60W) and SST-150E (150W) are surface mount electronic transformers. They have a built-in on-off switch and are designed to be used at the beginning of a linear track run. Remote transformers may also be used. Any enclosed unit from the EN-12 electronic transformer series will be a good choice, the exact model number being dependent on your system wattage. The SRT-300M (300W), SRT-500M (500W), SRT-600M (600W) and SRT-1000M (1000W) are magnetic transformers. Magnetic transformers have large system capacities and are available as 12V and 24V.

5. Why do you offer both 12 and 24 voltage transformers?

12 volt is the most common type of low volt lighting but is limited in its ability to support higher wattage loads or longer runs. 12 volts is best for runs of less than 20 feet. 24 volts is more useful in a long run.

6. You offer a 1000 watt transformer, does this mean I can run 1000 watts on a track?

No, The track has wattage limits that must not be exceeded. The limit is 240 watts for a 12 volt system and 480 watts for a 24 volt system. The outputs of larger capacity transformers can be split into multiple runs.

7. What is the capacity of the Linear System track?

The track has 12 gauge solid copper conductors and is rated for 20 amps. That is the reason for the wattage limits mentioned above.

8. What do you mean, when you say “a run” of track?

A run is defined as a transformer, the wires from the transformer leading to a live end connector, and the length of track.

9. Your instructions state that you should use 12 gauge wire when feeding the live end from the transformer. Why?

The track is rated for 20 amps. A 12 gauge wire is needed to handle the load.

10. Can the Linear System be dimmed?

Yes, When using the SST series or EN-12 series electronic transformers, electronic low voltage dimmers are recommended. When using the SRT series magnetic transformers, the system will require the use of low voltage magnetic dimmers.

11. I want to use the Linear Track for under cabinet lighting. Which bulbs should I use, and how far apart should I space them?

To achieve a medium light level, we recommend 10 watts per foot. This makes calculations easier. You can then use the SBH-110 fixtures with 5W lamps spaced every six inches, for example. The SF-209, SF-202 and SF-211 are also a good choice for cabinet lighting applications.

12. How do I suspend a Linear Track from the ceiling? What type of accessories do I need?

You must use the track carrier (SC4, SC8), which sold separately. It provides the point of attachment for the suspension kit and provides rigidity to the track. The aircraft cable suspension kit (SCK) consists of two canopies, cables, and hardware. The electrical feed is made through a flexible wire and a live end (SLE), sold separately. The cables can be adjusted to any length up to 48”.

13. In what applications do I need to use a track carrier? Can I paint the track carriers?

You will require track carriers when suspending the track from the ceiling. The track carrier provides rigidity and a finished look. They are made of an extruded aluminum, and are available in black, white or platinum in 4’ and 8’ lengths. You may paint them to color-match any interior.

Contact our WAC Lighting Specialist for more information, 800.526.2588.

14. Can the SJS jumper connector be lengthened?

Yes, use 12 AWG, 300V, 60°C rated stranded wire.

15. Can I extend a linear fixture like the regular track system?

No, The adapter is too small to allow any modification.

16. Is the Linear System suitable for use in an outdoor setting?

No, the Linear System is intended for use in dry locations only.

17. Is the Linear System conduit feedable?

The surface mount transformers have an adapter to accept BX or non-metallic sheathed cable connectors on the primary side. You can also use the SBXLE, it provides a standard sized opening that accepts BX or non-metallic sheathed cable wires and encloses the live end.

18. Are all of the connectors feedable?

Only the live end (SLE) accepts power wires, even if you are using the SFC-150E floating canopy feed, you will need to order one or more live ends (see diagrams 1 & 2).

19. If using the SFC-150E Floating Canopy Connector with transformer, do I need a live end?

Yes, the SFC-150E floating canopy conceals a 150W electronic transformer, and wire connections. There are four "breakouts" in the floating canopy. Tracks can enter to form an "I", "L" or "X" configuration. Live ends (SLE) are required to power the tracks from a floating feed (see diagram 1 & 2).

20. Can the floating canopy connector power a track anywhere along the length?

The floating canopy does not power a track. Power feed is always accomplished through a live end connector, which is sold separately. The canopy serves to conceal the live end wiring. The SFC-150E also conceals a transformer (see diagrams 1 & 2).

If you wish to power two track sections using a power source at the center joint you would need two live-ends at each track and one SFC.

DIAGRAM 1

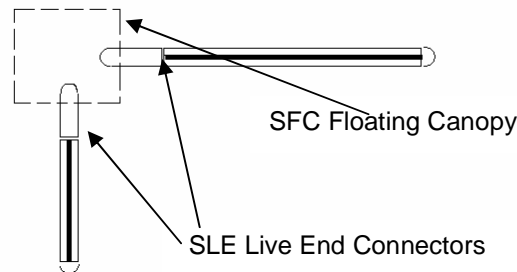

If powering from one source simply continue the run with the connector. The SFC conceals the outlet box.

DIAGRAM 2

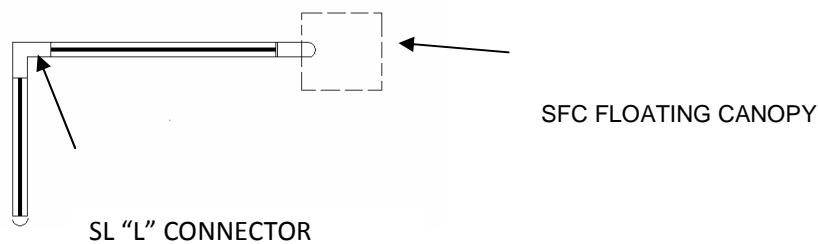

21. Do you have a device that enables me to mount a track to the wall?

No, the linear system is not designed to be mounted to a wall.

22. How do I achieve the look of a "hidden light source" under my cabinet?

You may use the SLB Light Baffle (available in white or platinum) to shield the light source. They come in 4' or 8' sections, are field cuttable, and can be painted to color-match any surface.

23. How many live ends do I need for a 40' run of linear track around the perimeter of a room using SBH-101 fixtures?

The number of live ends required depends on the load. For example, if you are putting (4) SBH-101 (3W each) fixtures per foot. That is 12 watts per foot x 40ft = 480 total watts.

The 3W lamp is only available in a 12 volt version. To avoid a voltage drop, we suggest that you use a 500W transformer which has (2) 250W 12volt outputs and (2) live ends. Your two runs of 240 watts do not exceed the tracks capacity or the 20ft run length limitation.

- 24. I have a 4' linear track with 35W fixtures on it. Can I hook up two transformers to the track because one is not strong enough to power all the fixtures?**
No, divide the track in two sections and two power feeds (live ends). Wiring two transformers together will cause immediate system failure.
- 25. I need some track lighting for use in the UK. Are linear system rated 50/60 Hz?**
You may use the EN-12 Series or the SST Series electronic transformer in this application. They are rated 50/60Hz. The magnetic SRT series transformers are only rated 60Hz.
- 26. Will any of your linear track heads take color lenses?**
Yes, all of the small halogen fixtures may be fitted with a variety of color lenses, filters and louvers. They simply replace the clear lens that comes with the fixture. The only exception is the SF-214 that requires the addition of a lens clip only available in the MR16 size.
- 27. What are the differences between the Xenon and Halogen lamps/fixtures? Are there any advantages of one over the other?**
The two are designed for specific applications. The halogen fixtures employ MR11 and MR16 lamps and provide a higher level of lighting. The Xenon lamp fixtures employ smaller wattage lamps and are designed for use where a subtle light source is required – cove lighting, in/under cabinet, toe space, etc. The xenon light burns cooler than the halogen lamp, however, the halogen light emits a whiter color. The xenon fixtures are also much more energy efficient.
- 28. I noticed that the socket wires on linear track heads are short and don't permit the light to be directed toward the track. Is this intentional?**
Yes, the directed heat can damage the ceiling or track. They are designed to shine away from the track.
- 29. Can I install Quick Connect™ fixtures on the Linear system?**
Yes, you may connect Quick Connect™ fixtures to the Linear system using the adapter (SADP).
- 30. Can linear fixtures be mounted as monopoints?**
No, however many of the styles were derived from the standard low volt track head series, which can be made as monopoints.

120V TRACK SYSTEM - SINGLE CIRCUIT TRACK – FREQUENTLY ASKED QUESTIONS

- 1. Are your track lighting systems U.L. listed?**
Yes, they are U.L. & C.U.L. listed.
- 2. Why do you have three different track systems?**
Having three systems gives us flexibility in meeting the needs of all our customers. By having systems that are compatible with other track systems in the marketplace, our fixtures are available for retrofit jobs. Some customers stock more than one system to expand their selections.
- 3. Is there an advantage of one system over another?**
No, each system has its own mechanical and design features. It's a matter of personal preference.
- 4. Do you need different types of track fixtures for the L, H or J track systems?**
Yes, the track fixture must be compatible with the track being used. For example, an L track fixture can only be used on a type L track system.
- 5. Being a new WAC distributor, which system would you recommend that we carry?**
The "H" system. It has the most available accessories and is stocked in greater quantities.
- 6. Can your track heads be used with other UL manufacturers track?**
It depends on the manufacturer. We have listed our heads for use on other major brands of track. Check with your distributor or contact our WAC Lighting Specialist at 800.526.2588.
- 7. The "L" series track head is extremely hard to insert into original Lightolier tracks. I'm afraid I might break the fixture. What should I do?**
It is a very tight fit, but nonetheless, it will work. As long as the track head goes in once, it is loosened, and can then easily be placed anywhere along the length of the track.
- 8. Since the floating canopy powers the track anywhere along its length, can it be placed at the end?**
Yes, but not all the way at the end. Unlike the live end, it cannot be used as an end piece. It can only be placed next to the end cap at the furthest point.
- 9. How do I extend a line voltage track head?**
Only line voltage fixtures from the "H" system may be extended. We offer 18", 24", 36" and 48" lengths (H18, H24, H36 and H48).
- 10. Can the line voltage extensions be shortened?**
No, they are one integral piece and cannot be shortened.
- 11. What accessories will I need to suspend my tracks 3' on a sloped ceiling? How do you bring power from the end of the rod to the track?**
You will need 36" suspension kits (SK36), and sloped ceiling adapters (SK14). You will also need a live end to power the track. The wire goes to a live end connector (or an "L", "X", "T", "FLX", "I-PWR") on the end. Refer to the installation instructions that come with the suspension kits for wiring information.

Basically, you will require two suspension kits for a 2' or 4' track, and three kits for 6' or 8' track sections.
- 12. How do I suspend a track 6½' from the ceiling?**
To get 6½', you need a basic SK48 suspension kit, plus two 36" rods (R36), two couplers (RI), and an SK05 adapter kit to field cut the suspension rod. As with all unique or custom installations, feel free to contact our WAC Lighting Specialist at 800.526.2588.
- 13. I am trying to install a live end into a track, but the end cap keeps coming off. What am I doing wrong?**
The live end requires a fair amount of pressure to insert, and subsequently the end cap and bus wires may push out of the opposite end of track if it not braced against a secure surface. Brace the track and insert the live end. There should be no bus wires extruding from the opposite end if installed correctly.
- 14. How can I tell the difference between L, H, and J fixtures?**
The overall look is exactly the same. They differ in the way they each fit into the track. The adapter of a "H" fixture has three silver colored contacts – two on one side, and one on the other. An "L" fixture has two silver contacts shaped like a propeller. And the "J" fixture has 2 rounded contacts and one side is marked "P". The "J" fixtures will fit our "J2" two circuit track, by pulling up the contact marked "P", and inserting a "J-CLIP" to hold it in place.

15. What accessory will I need if I want to hang a 10 pound chandelier off my track?

You need a suspension loop (X-LOOP) which accepts chain-hung fixtures up to 35 pounds and provides a connection point to the fixture powered from the track.

16. Which connectors are power feedable?

The chart below outlines all of our WAC Lighting "connector" accessories:

COMPONENT	H	L	J
Floating canopy	Yes	Yes	Yes
Mono Point	Yes	Yes	Yes
Straight line connector with dead end	No	No	No
Straight line connector with power feed	Yes	Yes	Yes
Straight line connector	No	No	No
"L" connectors	Yes	Yes	Yes
"T" connector	Yes	No	Yes
"X" connector	Yes	No	Yes
Flexible track connector	Yes	Yes	Yes
Live end connector	Yes	Yes	Yes
Live end connector for BX cable	Yes	Yes	Yes

17. How many Live Ends do I need for a 30' run of track?

The number of live ends required depends on the load, and not on the length. The track is able to accommodate 20 Amp, at 80% capacity, i.e. 16 Amp. That works out to 1920 watts maximum. Say, you are putting (30) LHT-180L-WT (75W) fixtures into the 30' of track.

- Watts/ Volts = Amps
- Each 75W fixture will draw $75/120 = 0.625$ Amps
- (30) 75W fixture will draw $0.625 \times 30 = 18.75$ Amps

Since the maximum load of the track is 16A, you will need 2 power feeds for 18.75Amp.

18. If your track can accommodate 20 Amps, why do you advise to use only 80% of capacity?

The track can fully handle 20 Amps, but because of field installation conditions such as the quality of existing building wiring, track distance run, number of connections, etc., it is common practice to de-rate the track by 20%. An additional benefit of using a conservative load factor is that you have the opportunity to add new fixtures to your track in the future if needed.

19. Do you have a device that enables me to mount a track away from the wall?

The TBKT will do just that, the extension length is 24".

20. I need some track lighting for use in Europe, is your track lighting rated 50/60 Hz?

Yes, all our track is rated for 50/60Hz.

21. Which track heads would you recommend for use in an outdoor restaurant by the sea?

Our track systems and most others are not rated for outdoor use.

22. Do you have a low profile track head for use in a kiosk?

Yes. In the low voltage style most of the track heads would be considered to be small profile, however the series 802, 809, 846, and 866 would all be good choices. In a line voltage style, the #178 is a small track head that will handle all "A", "PAR" and "R" lamps which would make it a very versatile option. These are all available for our three track systems.

23. Will any of your track heads take color lenses?

Yes, in fact, we have a wide variety of color lenses, filters and louvers to accommodate both the MR16 and MR11 size fixtures. They simply replace the clear lens that comes with the fixture. Thicker lenses and louvers may not be adaptable to all styles, See page 193-194 of WAC Lighting catalog or our website, www.waclighting.com, for our compatibility matrix or contact our WAC Lighting Specialist at 800.526.2588 for any questions.

24. How do I order your line voltage flexible fixtures?

Our line voltage flexible fixtures are adaptable to all three of our track systems and as surface mounts (see questions on surface mounts):

- H track - 3-wire track (HTK-024/HTK-048)
- L track - 2-wire track (LTK-024/LTK-048)
- J track - Wide 2-wire track (JTK-024/JTK-048)
- Surface mounts (MO-024/ MO-048)

120V TRACK SYSTEM - TWO CIRCUIT TRACK LIGHTING – FREQUENTLY ASKED QUESTIONS

1. Is the WAC Lighting J2 style two-circuit track system U.L. listed?

Yes, it is U.L. & C.U.L. listed.

2. What's the difference between two-circuit and single-circuit track?

You can think of two circuit track as two tracks combined as one. Two-circuit track enables the use of two separately controlled circuits on one section of track. The two-circuit track can be wired with two separate feeds. Each track circuit can then handle up to 2400 watts (de-rated to 1920 usable watts is recommended). This saves on installation costs by eliminating the need for separate runs. Another option is to use one circuit feed and control it with two switches.

3. Do all of your track heads work on the two-circuit track?

No, only the JHT & JTK style heads work with the J2 style two-circuit track. These track heads work on the first circuit in their standard configuration and then can be adapted to work on the second circuit with the addition of the J-CLIP accessory.

4. How do I get the track heads to work on the second circuit?

On our JHT and JTK style heads, one of the contacts is marked with a "P". Use a needle nose pliers or similar tool to raise the contact, and then use a J-CLIP to hold it in place. This raised contact will make contact with the second circuit wire.

5. What accessories will I need to suspend my tracks 3' on a sloped ceiling? How do you bring power from the end of the rod to the track?

You will need 36" suspension kits (SK36), and sloped ceiling adapters (SK14). You will also need a live end to power the track. For our 2-circuit track, we offer the option of using a wireway - model # J2-WCOV that can conceal the wire 10 inches from the rod to the live end.

Refer to the installation instructions that come with the suspension kits for wiring information.

Basically, you will require two suspension kits for 4' track, three kits for 6' or 8', and four kits for the 12' track section.

6. How do I suspend a track 6½' from the ceiling?

To get 6½', you need a basic SK48 suspension kit, plus two 36" rods (R36), two couplers (RI), and an SK05 adapter kit to field cut the suspension rod. As with all unique or custom installations, feel free to call the technical department at WAC Lighting with any questions.

7. Are the tracks cuttable in the field?

Yes, follow the procedure explained in the instructions.

8. I do not see a floating canopy option for your J2 two-circuit track. How do I make a clean connection along my track?

You will want to use the octagon box cover (J2-UCP) and I-Power Connector (J2-IPWR). This accessory provides a clean appearance that can go over any of our J2 track connections. Just remove the plastic cover from the connector and the J2-UCP becomes the new cover.

9. I am trying to install a live end into a track, but the end cap keeps coming off. What am I doing wrong?

The live end require a fair amount of pressure to insert, and subsequently the end cap and bus wires may push out of the opposite end of the track if not braced against a secure surface.

10. If your track can accommodate 20 Amps on each circuit, why do you advise only using 80% of the capacity?

Each circuit can fully handle 20 Amps, but because of field installation conditions such as the quality of existing building wiring, track distance run, number of connections, etc., we advise de-rating the track by 20%. An additional benefit to using a conservative load factor is that you have the opportunity to add new fixtures to your track in the future if needed.

11. Can two circuit track be dimmed?

That depends on several factors. Fluorescent or metal halide track heads can not be dimmed. Incandescent fixtures may be dimmed on one of the two circuits. The dimmer should be one with a grounded neutral connection. Additionally low volt track heads should have an electronic low voltage dimmer switch.

12. Do you have a device that enables me to mount a track from the wall?

The (TBKT) wall mount track bracket allows you to mount your track 24" from the wall.

13. Which track connectors for your J2 series are power-feedable?

The chart below outlines all the connector accessories:

COMPONENT	Power Feedable?	Part Number
Straight line connector with dead end	No	J2-IDEC
Straight line connector with power feed	Yes	J2-IPWR
Straight line connector	No	J2-I
"L" connectors	Yes	J2-LLEFT, J2-LRIGHT
"T" connector	Yes	J2-T
"X" connector	Yes	J2-X
Flexible track connector	Yes	J2-FLX
Live end connector	Yes	J2-LE
Live end connector for BX cable	Yes	J2-BXLE
T-Bar End Feed	Yes	J2-TBLE

LARC – FREQUENTLY ASKED QUESTIONS

1. Are your LARC Precision Track fixtures U.L. listed?

Yes, they are U.L. and C.U.L. listed.

2. How do you adjust the LARC Fixtures?

Horizontal and vertical adjustments can be made by rotating the fixture on either of its axis. Degree indicators are printed on the fixtures for easy adjustment and aiming.

3. What type of transformers are included with the low voltage LARC Fixtures?

The low voltage LARC Fixtures come with an integral electronic low voltage transformer. The advanced technology of the transformer features auto-reset, soft start and short circuit protection. Soft start protects lamp filaments from abrupt inrush current that shortens lamp life.

4. Can I use lens accessories on the LARC Fixtures?

Yes, the LARC Fixtures allow the use of up to two lenses and one accessory. (eg: UV filter lens, color filter lens & honeycomb louver)

5. When would two accessories be called for?

It depends on the architectural design but mostly they used on commercial applications such as museum, high-end restaurant or gallery store. You might like to use a colored lens with a honeycomb louver to reduce side glare, or perhaps a UV filtering lens with a honeycomb louver, or colored lens.

6. Your catalog states low voltage models using MR16 lamps are available in 75 watt versions, but your lamp chart shows 71 watt lamps, Why is that?

Most lamp manufacturers offer a slightly reduced wattage version because it has the best combination of lamp life and lumen level characteristics.

7. What type of track can I use with the LARC Fixtures?

The LARC Fixtures work with our WAC H, L, J and J2 system tracks. The addition of the “J-CLIP” allows the standard luminaire to engage the second circuit of the two circuit track.

8. Are the LARC Fixtures compatible with any other manufacturers track systems?

Yes, our track heads are U.L. listed for use with several other manufacturers track systems. Check with our WAC Lighting Specialist at 800.526.2588 for current compatibility information.

9. What are the features of the LARC fixture?

The LARC Fixtures have the look and features often required for high profile applications where the fixtures need to provide precise control and adjustability. These specification grade die cast aluminum units have a thick powder coat paint finish, ratchet action adjustment with integral aiming indicators. The threaded lens ring holds of up to two lenses and one accessory. (eg: cross baffle) The socket wires are concealed for a clean appearance. These features distinguish the LARC Fixtures from standard track heads.

10. What type of lamps are compatible with LARC Fixtures?

We offer a variety of lamping options depending on the fixture purchased, such as MR16, AR111, PAR30, Metal Halide PAR30, HID CDM AR111, HID ES16 and HID CDM T4. Each LARC Fixture offers different lamping options, please see our WAC website to choose accordingly.

PRECISION SPOTS – FREQUENTLY ASKED QUESTIONS

1. Are your Precision Spots U.L. listed?

Yes, they are U.L. and C.U.L. listed.

2. How do you adjust the Precision Spots?

Vertical adjustment is made by loosening the two side locking screws Horizontal adjustment is made by rotating the spot on its axis. Degree indicators are printed on the fixtures to make it easy to maintain the aiming angle after cleaning or re-lamping.

3. What type of transformers are included with the low voltage Precision Spots?

The low voltage Precision Spots come with an integral electronic low voltage transformer. The advanced technology of the transformer features auto-reset, soft start and short circuit protection. Soft start protects lamp filaments from abrupt inrush current that shortens lamp life.

4. Can I use lens accessories on the Precision Spots?

Yes, the Precision Spots allow the use of two lens accessories within the die cast lens cap. The 713 and 733 units use exposed Par lamps and do not have a lens accessory option.

5. When would two accessories be called for?

It depends on the architectural design but mostly they used on commercial applications such as museum, high-end restaurant or gallery store. You might like to use a colored lens with a honeycomb louver to reduce side glare, or perhaps a UV filtering lens with a honeycomb louver, or colored lens.

6. Your catalog states low voltage models using MR16 lamps are available in 75 watt versions, but your lamp chart shows 71 watt lamps, Why is that?

Most lamp manufacturers offer a slightly reduced wattage version because it has the best combination of lamp life and lumen level characteristics.

7. What type of track can I use with the Precision Spots?

The Precision Spots work with our WAC H, L, J and J2 system tracks. The addition of a "J-CLIP" allows the standard luminaire to engage the second circuit of the two circuit track.

8. Are the Precision Spots compatible with any other manufacturers track systems?

Yes, our track heads are U.L. listed for use with several other manufacturers track systems. Check with the factory or our WAC Lighting Specialist at 800.526.2588 for current compatibility information.

9. When would I want to use the Precision Spots over a standard track heads?

The Precision Spots have the look and features often required for high profile applications where the fixtures need to provide precise control and adjustability.

These specification grade die cast aluminum units have a thick powder coat paint finish, ratchet action adjustment with integral aiming indicators and locking adjustability. The threaded lens ring holds of up to two captive accessories. The socket wires are concealed for a clean appearance. These features distinguish the Precision Spots from standard track heads.

10. Do you have any metal halide or compact fluorescent Precision Spots?

We offer a variety of lamping options depending on the fixture purchased, such as MR16, AR111, PAR30, Metal Halide PAR30, HID CDM AR111, HID ES16 and HID CDM T4. CFL and HID lamps are not available in the Precision Spot family at this time. Please check with our WAC Lighting Specialist at 800.526.2588 regarding upcoming product introductions.

LOW VOLTAGE TRACK FIXTURES – FREQUENTLY ASKED QUESTIONS

1. Are your track lighting systems UL listed?

Yes, it is UL & CUL listed.

2. Do you need different types of track fixtures for the L, H or J track systems?

Yes, the track fixture must be compatible with the track being used. For example, an L track fixture can only be used on a type L track system.

3. Why do you have three different track systems?

Having three systems gives us flexibility in meeting the needs of all our customers. By having systems that are compatible with other track systems in the marketplace, our fixtures are available for retrofit jobs. Some customers stock more than one system to expand their selections.

4. How can I tell if a fixture is low or line voltage?

The low voltage fixture has an oblong transformer box, whereas the line voltage fixture has a simple square adapter.

5. You offer two types of framing projectors. What is the difference between the 008FP and the 009?

The 008FP has one lens and is good for forming a rectangular area of light on an art work. The 009 has two lenses for focusing and producing a larger pattern range. The 009 also allows the use of a gobo, which is a type of stencil for projecting logos or images on a wall. The 008FP is an attachment to the 007 fixture, while the 009 is a complete fixture.

6. Do you have barn doors available for your low voltage track heads?

Our series 801 track head has the option of barn doors (801-BD). This is our only low voltage track head with a specific barn door option.

7. How do I extend a low voltage track head?

The low voltage track heads with extensions are made to order at our facility. We have 6", 12", 18", 24", 36" and 48" drops. All standard low voltage track heads may be fitted with an extension. Simply add the desired extension length to the track head when ordering. For example: X18-HHT-809-WT

8. Can the low voltage extensions be field shortened?

No, they are one integral piece and cannot be field shortened.

9. How do I order a low voltage track head as a 75W unit?

The standard version of track heads is 50W max, adding the letter "L" as a suffix to the model number signifies the 75W max version. Using the 808 round back as an example, See below for ordering information for a black 50W and 75W unit. Notice that you use the "L" suffix when ordering a large capacity track head.

WATTS	VOLTAGE	3-WIRE	2-WIRE	WIDE 2-WIRE
50W	120V-12V	HHT-808	LHT-808	JHT-808
75W	120V-12V	HHT-808L	LHT-808L	JHT-808L

10. Since the integral transformers for the low voltage track heads are electronic, what type of dimmers would I require?

We recommend the use of an electronic low voltage dimmer.

11. Do you have any track heads in brushed nickel?

Yes, some of our more popular styles are available in brushed nickel. For example, LHT-809-BN. Check the current WAC Lighting catalog or our website, www.waclighting.com, for finish options.

12. I would like to use a low voltage fixture as a monopoint, but the transformer doesn't fit on the monopoint accessory. What do you suggest?

You may order any low voltage style as a surface mount fixture on an LP or ME canopy base (with the transformer hidden inside the canopy) or the MI or MO base (with a remote transformer). See the surface mount section of our current catalog or our website, www.waclighting.com, for further details.

13. Will any of your track heads take color lenses?

Yes, in fact, we have a wide variety of color lenses, filters and louvers to accommodate both the MR16 and MR11 size fixtures. They simply replace the clear lens that comes with the fixture. Thicker lenses and louvers may not be adaptable to all styles. See page 193-194 of WAC Lighting catalog or our website, www.waclighting.com, for compatibility matrix or feel free to call with any questions, 800.526.2588.

14. How can I tell the difference between an L, H, J, fixture?

The overall look is exactly the same. They differ in the way they each fit into the track. The adapters look different on top. Page 206 of WAC Lighting catalog and web site show the visual differences for easy identification.

15. You also offer a J2 track, which fixtures will fit that?

All "J" series fixtures have a movable contact (marked with a "P") that will fit in the J2 two circuit track. The contact is raised as needed to fit the second circuit and then secured by a "J-CLIP".

16. What type of track system would you recommend for my application?

- a) Aesthetic considerations aside, choose the lamp beam pattern appropriate for your mounting height and distance from the objects being illuminated.
- b) Now select your track type. Do you need one-circuit or two-circuit track? In most cases single circuit will be fine. The H style track is the most common in the marketplace; consequently our stock position on this is the highest.

A simple installation consists of the track, track heads, and live end feed or floating canopy to power the track. However, the desired configuration of the track, mounting type, total wattage of the system, are among some of the aspects needing to be considered. It is always best to start by sketching out the room and where you want to mount the track, from there it becomes easier to calculate the parts list for the track system. A separate design guide for track systems is available by request from your local WAC sales representative.

LEDme™ TRACK LUMINAIRES – FREQUENTLY ASKED QUESTIONS

1. Are the LEDme™ track heads dimmable?

No, currently LEDme™ track heads are not dimmable.

2. Are the LEDme™ track heads suitable for lens accessories?

Yes, you can fit up to two color lenses or accessories on the LEDme™ track heads. Please visit our website or see page 193-194 of the catalog for our lens accessory options.

3. How is the life expectancy calculated for LED products?

Unlike halogen calculations where the lamp life is rated at the point where 50% of the lamps fail, LEDs life expectancy is the point which the lamp is at 70% of its original output (brightness). All of our LED track products are listed with a 50,000 hour life.

4. What is the potential life of the LED lamp in the LEDme™ track luminaires?

It has a potential life of 50,000 hours.

5. How hot is the LEDme™ track luminaires is going to get and how much heat is it going to project?

There is a built-in heat sink, so the track head will stay relatively cool. There is no heat projected from the LED track luminaire.

6. If I ordered a narrow beam track head, is it possible to convert to a narrow flood beam?

Yes, you can order LED-81-BSL to replace the current LENS-20-CL

COMPACT FLUORESCENT TRACK LUMINAIRES – FREQUENTLY ASKED QUESTIONS

1. Are the Compact Fluorescent track fixtures U.L. listed?

Yes, they are U.L. & C.U.L. listed.

2. What is the warranty of your compact fluorescent track fixtures?

The standard WAC Lighting warranty for the fixture is 5 years. The ballast's are covered by separate ballast manufacturer's warranty.

3. Is a compact fluorescent track luminaires more energy efficient than an incandescent track luminaires?

Yes, compact fluorescent lamps are very energy efficient. You can expect about four times the light output per watt from a compact fluorescent lamp as compared to an incandescent.

4. Why are these track luminaires called “wall washers” in my WAC Lighting catalog?

These track luminaires are designed to evenly illuminate a large area on a wall. They are often used for lighting large vertical display areas. They are also a good energy efficient choice for providing general ambient light into a space when mounted in high ceiling applications.

5. Can these compact fluorescent track heads be dimmed?

No, they are only available with standard (non-dimming) electronic high efficiency ballast.

6. I notice you refer to “biax™” and “double biax™” as the lamps for your fixtures, what is that?

The terms “biax™” and “double biax™” are actually terms that GE uses in referring to this particular type of compact fluorescent lamp. Other manufacturers may use a different name for the same lamp. The table below is a general guide to cross reference different brand names (see the appropriate lamp manufacturer website for their most current offerings).

GE	OSRAM SYLVANIA	PHILIPS
BIAX	DULUX L	PL-L
DOUBLE BIAX	DULUX D/E	PL-C

7. Can I extend the CFL (compact fluorescent lights) fixtures from a track?

No, extensions are not available for these units.

8. Can I install the CFL fixtures on a suspended track?

Yes, you can install them on a track that has been suspended from the ceiling, provided the track has adequate support.

9. Are your fixtures supplied with lamps?

No, lamps can be purchased from your local electrical supplier.

10. Can I use these fixtures on your standard H / J / L or J2 track, or do I need a special track?

Yes, these fixtures will work with all of our existing tracks, there is no need for a special track. On our 2 circuit J2 track, a J-CLIP is needed to work on the second circuit.

11. Do the louvers come with the fixtures? What colors are available?

The louvers are made of aluminum. They are available in white, black and clear specular, they are sold separately.

METAL HALIDE (HID) TRACK LUMINAIRES – FREQUENTLY ASKED QUESTIONS

- 1. Are the Metal Halide track fixtures U.L. listed?**
Yes, they are U.L. & C.U.L. listed.
- 2. What is the warranty of your Metal Halide fixtures?**
The standard WAC Lighting warranty for the fixture is 5 years. The ballast's are covered by separate ballast manufacturer's warranty.
- 3. Can these fixtures be dimmed?**
No, these Metal Halide track heads are not dimmable.
- 4. When I turn on these fixtures, they don't come to full brightness right away, is that normal?**
Yes, a metal halide lamp does not reach full light output immediately. It will take several minutes before the lamp reaches full light output.
- 5. Can I extend the Metal Halide fixtures from a track?**
No, extensions are not available for these units.
- 6. Can I install the Metal Halide fixtures on a suspended track?**
Yes, you can install them on a track that has been suspended from the ceiling, provided the track has adequate support. We recommend four supports for each 8' section of track.
- 7. Can I use these fixtures on your standard H / J / L or J2 track, or do I need a special track?**
Yes, these fixtures will work with all of our existing tracks, there is no need for a special track. On our 2 circuit J2 track, a J-CLIP is needed to work on the second circuit.
- 8. In what type of application would I use a Metal Halide track head?**
These fixtures are intended for use where a high level of light is needed and true color rendering is important. Typical applications include high profile display and merchandise lighting. Another good application for these units is to use them where you have an unusually high ceiling height.
They would not be practical for most residential settings.
- 9. Why are these heads not practical for a residential setting?**
Metal halide lamps do not provide instant on operation they take several minutes to startup and again to relight after switching off.
- 10. You offer a choice of a magnetic or an electronic ballast for each fixture, what is the difference?**
An electronic ballast consumes less energy, and has voltage regulation features that extend lamp life. Magnetic ballast's offer a lower initial outlay.
- 11. What is a ballast and what does it do?**
A metal halide lamp requires a higher amount of voltage to 'start up', then a lower voltage to operate. A ballast provides the lamp with these different voltage requirements.
- 12. Why is there a switch on the back of your metal halide track heads.**
The switch is used for re-lamping the fixtures without powering down the entire track.
- 13. Are these fixtures supplied with lamps?**
No, lamps can be purchased from your local supplier.
- 14. I see that these fixtures use PAR lamps, are they standard PAR lamps or do I need to purchase special ones?**
These fixtures require the use of a metal halide type PAR lamp.
- 15. Can I expect more light out of a metal halide compared to a similar wattage incandescent? Are they energy efficient?**
Yes, they are energy efficient, and you can expect about four to five times the light output per watt from a metal halide lamp.
- 16. What is the average rated life of a metal halide lamp?**
The average lamp life of a PAR type metal halide is 9000 to 12000 hours.
- 17. Can I get any other styles of Metal Halide track heads?**
Although the style remains the same, there are 5 versions of these fixtures to allow various lamp and wattage selections and ballast types. The current style provides a very clean and low profile appearance that blends in well with many environments.
- 18. What is a ballast and what does it do?**
A metal halide lamp requires a higher amount of voltage to 'start up', then a lower voltage to operate. A ballast provides the lamp with these different voltage requirements.
- 19. Why is there a switch on the back of your metal halide track head?**
The switch is used for re-lamping the fixtures without powering down the entire track.

LINE VOLTAGE TRACK FIXTURES – FREQUENTLY ASKED QUESTIONS

1. Are your track lighting systems U.L. listed?

Yes, they are U.L. & C.U.L. listed.

2. Do you need different types of track fixtures for the L, H or J track systems?

Yes, the track fixture must be compatible with the track being used. For example, an L track fixture can only be used on a type L track system.

3. Why do you have three different track systems?

Having three systems gives us flexibility in meeting the needs of all our customers. By having systems that are compatible with other track systems in the marketplace, our fixtures available for retrofit jobs. Some customers stock more than one system to expand their selections.

4. How can I tell if a fixture is low or line voltage?

The low voltage fixture has an oblong transformer box, whereas the line voltage fixture has a simple square adapter.

5. Are your line voltage track heads dimmable?

Yes, our line voltage track heads are fully dimmable with any incandescent dimmer.

6. Do you have barn doors options available for your line voltage track heads?

Our series 024, 048, 178, and 188 track heads have the option of barn doors. The barn doors are available in Black (BK), Brushed Nickel (BN), and White (WT). Sizes are available for PAR20, PAR30, and PAR38 lamps.

7. How do I extend a line voltage track head?

Only the fixtures from the 3-wire "H" system may be suspended. We offer 18", 24", 36" and 48" lengths (H18, H24, H36 and H48).

8. Can the line voltage extensions be shortened?

No, they are one integral piece and cannot be shortened.

9. Do you have a very low profile track head for use in a kiosk?

The line voltage style model 178 is a smaller profile track head that will handle all "A", "PAR" and "R" lamps.

10. How can I tell the difference between an L, H, J, fixture?

The overall look is exactly the same. They differ in the way they each fit into the track. The adapters look different on top. See page 206 of WAC Lighting catalog to show the visual differences for easy identification.

11. You also offer a J2 track, which fixtures will fit that?

All "J" series fixtures have a movable contact (marked with a "P") will fit in the J2 two circuit track. The contact is raised as needed to fit the second circuit and then secured by a "J-CLIP" see page 212 of WAC Lighting catalogue.

LINE VOLTAGE PENDANTS – FREQUENTLY ASKED QUESTIONS

1. Are the WAC Lighting Line Voltage Pendants U.L. listed?

Yes, they are U.L. & C.U.L. listed.

The single monopoint unit (PLD-MO96) is ETL listed.

2. What are the different ways I can order the pendant fixtures?

The pendants are ordered as single line item, for example, LTK-513WT/BN. First you determine the hanging method than choose your shade and socket set color. You have the following hanging options:

A. As part of a track system, you will simply determine the track system:

- For the H track order the HTK.
- For the L track order the LTK
- For the J track order the JTK.
- For the J2 two circuit track order the JTK along with the proper amount of J-CLIP's.
- For Flexrail1™ single circuit bendable track order the HM1

OR

B. As a single monopoint light:

- Order the (PLD-MO96) socket set which comes with a 4½" canopy that covers a standard junction box.

3. Can I get pendants longer than 8'?

They only come in one length - 96" from the factory. However, we can supply longer lengths of the same wire. Contact your local WAC Lighting representative or the WAC factory for additional ordering information.

4. Can the pendant fixtures be field shortened? If so, which end of the cord do I shorten?

Cord length adjustment is easily accomplished on track models by unscrewing the bottom portion of the holder, and trimming the socket wire to the desired length from the socket side, monopoints may be shortened at either end.

5. How can you mount a pendant light on a sloped ceiling?

The canopy or track fixture is installed as usual on the sloped ceiling. The cord makes the pendant hang straight.

6. What is included in the socket set?

The socket set includes the socket, a 96" 3 conductor cord, and a holding ring to secure the shade to the socket holder.

TRACK CURRENT LIMITER – FREQUENTLY ASKED QUESTIONS

1. Is the track current limiter U.L. listed?

Yes, they are U.L. & C.U.L. listed.

2. When do we need to use a track current limiter?

The WAC track current limiter is used in order to comply with California Title 24 or ASHRAE 90.1 requirement. If your area is covered by one of those regulation, you will need a track current limiter.

3. How does a current limited do?

If the track is overloaded, the current limiter circuit breaker will trip and shut down power to the track. The device may be reset when the overall sum of fixture wattage are reduced below the circuit breaker rating.

4. How do I order a track current limiter?

The current limiter can be used with our 120V track system (H, L, J and J2).

See page 214 of WAC Lighting catalog for ordering detail.

MULTIPLE RECESSED SPOTS – FREQUENTLY ASKED QUESTIONS

- 1. Are the multiple spots U.L. listed?**
Yes, they are U.L. and C.U.L. listed. You can find listed products at www.ul.com.
- 2. What are the different ways I can order the multiple spots?**
We offer low, line voltage and metal halide multi-spots in the following configurations:
See page 217-222 of WAC Lighting catalog for ordering detail
- 3. Can I dim these fixtures?**
The low voltage Multi-Spots can be dimmed with electronic low voltage dimmers. The line voltage PAR38 units can be dimmed with standard incandescent or low voltage dimmers. HOWEVER, our metal halide is not dimmable.
- 4. Are these fixtures adjustable?**
Yes, each lamp has 25° tilt and 360° rotation
- 5. Do you have these fixtures available for remodeling applications?**
No, these fixtures are designed for new construction applications or suspended ceilings.
- 6. Do these units come with hanger-bars?**
Yes, they come with hanger-bars as well as brackets to fit over T-Bars.
- 7. What do I get when I order a WAC Multiple Spot?**
The Multi-Spot is made up of two components, the housing and the trim. The housing comes ready for installation in the ceiling. The low voltage housings come complete with low voltage electronic transformers. The trim is a separate line item since you must choose your desired color. Both parts need to be ordered to have a complete unit.
- 8. Can each lamp be controlled individually?**
No, all lamps operate in unison.

LOW VOLTAGE RECESSED DOWNLIGHTING – FREQUENTLY ASKED QUESTIONS

1. Are these products U.L. listed?

Yes, they are U.L. & C.U.L. listed.

2. You have many categories of low voltage trim styles, how do I select one?

Trims are arranged by aperture size even though all use MR16 lamps (with the exception of the HR-D329 shower trim). We have 3" and 4" aperture sizes. The basic choices are based on aesthetics of the various trims.

3. How do I decide which trims fit which housings ?

Every trim has a series of corresponding housing choices. Consult the catalog or web site.

4. How do I choose a housing?

You need to first determine whether this is a new construction or a remodeling situation. Then determine if the housing will be in contact with insulation (I/C housing) or not (Non-IC). Next determine your wattage requirements. The greatest range of housing options can be found in the 4" Die-cast series. Check our catalog for dimensions and applicable trims. A matrix of our 4" magnetic transformer housings is shown below.

FEATURE	HR-8401H / HR-8401E	HR-8401HF	HR-8402H / HR-8402E	HR-8402HF	HR-8402HL	HR-8402HFL	HR-8403H	HR-8403HF
Wattage	50W	50W	50W	50W	75W	75W	50W	50W
Input	120V	277V	120V	277V	120V	277V	120V	277V
Usage	Remodeling	Remodeling	New construction	New construction	New construction	New construction	New construction	New construction
Lamp type	20-50W max MR16	20-50W max MR16	20-50W max MR16	20-50W max MR16	50-75W max MR16	50-75W max MR16	20-50W max MR16	20-50W max MR16
Insulation	3" clearance (Non I/C)	3" clearance (Non I/C)	3" clearance (Non I/C)	3" clearance (Non I/C)	3" clearance (Non I/C)	3" clearance (Non I/C)	Direct Contact (I/C)	Direct Contact (I/C)
Replacement Transformer	HR-8001	HR-8001F	HR-8002	HR-8002F	HR-8002L	HR-8002FL	HR-8003	HR-8003F

5. Can the trims be installed without a can or housing?

No, you must use a can or housing with the trims.

6. Is there a low voltage remodeling housing rated for insulation contact?

No, the IC rating is only found in new construction housings.

7. Can the hanger bars on your HR-8400 series new construction cans be moved to accommodate joists running perpendicular?

Yes, hanger bars can be used on all four sides of the housing.

8. Can your housings be used on a drop ceiling? If so, how?

Yes, use a new construction housings. The hanger bars rest on the top of the "T" bars and are secured in position.

- 9. Can these fixtures be installed in the bathroom?**
Yes, they are suitable for damp locations (porch or bathroom), but not wet locations (above a shower or outdoors).
- 10. I have a concrete ceiling, must I use housings with low volt trims?**
Yes, national electrical codes require the use of housings for all installations.
- 11. Can low voltage trims use accessory lenses?**
Yes, trims may be fitted with an accessory lens (such as a frosted or colored lens) in place of the clear glass lens supplied.
- 12. How do I know when to order sockets, and when not to order sockets?**
All housings are equipped with sockets. Only the HR-8425 requires a special socket, and it is supplied with the trim.
- 13. How much current does each 50watt downlight draw?**
 $50/120V = 0.42Amp$.
- 14. Do any of the downlights come with bulbs?**
No, you may purchase the MR16 lamps separately.
- 15. Why do I need to order the lamps separately?**
Mirrored reflector lamps like an MR16 come in a wide variety of beam spreads. Since we can not know which beam spread might be best for your particular installation, ordering the lamp separately allows you to select the best lamp for your project. You can contact our WAC Lighting Specialist at 800.526.2588 for assistance with proper lamp selection.
- 16. Why would I want to use a remote transformer separate from the housing?**
Some of the WAC housing did not have built-in transformer, therefore a remote transformer is necessary.
- 17. Why would I choose a magnetic transformer housing as opposed to an electronic model?**
You may want to utilize existing controls or dimming system. The magnetic transformer downlights require magnetic low voltage dimmers. The other primary use for magnetic models is in high heat or cold applications, since magnetic transformers are more tolerant of more unusual temperature environments.

METAL HALIDE DOWNLIGHTS – FREQUENTLY ASKED QUESTIONS

1. Are your Metal Halide downlights U.L. listed?

Yes, they are U.L. & C.U.L. listed.

2. What is the best application for a downlight utilizing a metal halide lamp?

These downlights are best used in areas where high foot candle levels, long lamp life and crisp white light are desired. Specific applications can include areas with high ceilings and retail environments. Additionally, any installation where you are concerned with long term economy and maintenance is a good candidate for a MH downlight installation.

3. Can these fixtures be installed in a gymnasium?

Although metal halide is used extensively in gyms, those fixtures are designed with wire cages to protect the lamps from being struck by a ball. Our down lights are for more subdued settings.

4. Do any of the fixtures come with the bulbs (lamps) included?

No, our metal halide downlights use lamps that are readily available in all suppliers.

5. Why are the lamps for metal halide so expensive compared to incandescent lamps?

In general, the longer the average life hours of the lamp the greater the initial cost. The average halogen incandescent Par lamp is rated for a 1500 hour life. The average metal halide Par lamp is 12,000 hours. In addition to longer life, a metal halide lamp provides more lumens per watt.

6. How do I choose between the different types of trims?

When you use a PAR lamp, the Step Baffle provides the cleanest aesthetics and the most diffused output. When you use an ES-16 lamp, the Open Reflector provides the best performance in terms of maximizing light output.

7. How do I decide on which ballast I should use in my application?

Your two choices are either magnetic ballast or electronic ballasted new construction housing. The electronic ballast is the most desirable because it offers higher efficiency, longer lamp life, and shorter strike and re-strike times. The magnetic ballasts offer a shorter initial startup time.

COMPACT FLUORESCENT DOWNLIGHTS – FREQUENTLY ASKED QUESTIONS

1. Are your Compact Fluorescent downlights U.L. approved?

Yes, they are U.L. and C.U.L. listed.

2. How do I decide between which housings to use?

We offer both single vertical lamp or double lamp horizontal housings. The vertical lamp position has superior photometrics but requires a high ceiling space. Evaluate your light level requirements and determine your lamp wattage. Consult your current WAC Lighting catalog or our website, www.waclighting.com, for fixture dimensions and trim selection.

3. Can your housings be used on a drop ceiling? If so, how?

Yes, on a new construction housing, the hanger bars rest on the T-Bars and are secured in position.

4. Can these fixtures be installed in a bathroom?

Yes, they are all suitable for damp locations (porch or bathroom) using any trim. Wet locations, above a shower or outdoors, require the use of specific lensed trims. Consult your current WAC Lighting catalog or our website, www.waclighting.com, for our current offerings.

5. Do any of the fixtures come with bulbs?

No, our Compact Fluorescent downlights use lamps that are readily available in all electrical supply centers.

6. Why would I want to use a Compact Fluorescent downlight instead of an Incandescent downlight?

Compact Fluorescent downlights provide the same output as incandescent lamps but use only ¼ the amount of energy. So you could use a 26W CFL unit in place of a 100W incandescent unit. In addition, the average life hours of compact fluorescent lamps far exceed the hours of incandescent lamps. Most fluorescent lamps are rated 10,000 hours as opposed to 1500 hours for a halogen Par lamp.

7. Do you have any Compact Fluorescent downlights that are Energy Star rated?

Yes, we have 5" and 6" Compact Fluorescent housings that are Energy Star rated.

8. Do you make Compact Fluorescent downlights that are bigger than 6"?

Yes, we have 8 inch trims and housings.

LINE VOLTAGE DOWNLIGHTS – FREQUENTLY ASKED QUESTIONS

1. Are your line voltage downlights U.L. listed?

Yes, they are U.L. and C.U.L. listed.

2. How do I decide between which housings to use?

First you need to determine whether this is a new construction or a remodeling situation. Then determine if the housing will be in contact with insulation (IC housing) or not (Non-IC). Next determine your wattage requirements. Finally check your current WAC Lighting catalog or our website, www.waclighting.com, for fixture dimensions and trims selection.

3. Can your housings be used on a drop ceiling? If so, how?

Yes, use a new construction housings. The hanger bars rest on the T-Bars and are secured in position.

4. I am not sure which trim I should use for my application, which type should I use for general ambient lighting?

Both the Basic Baffle and Open Specular will be good choices. The baffle helps reduce glare while the specular reflector will increase the spread of light from the fixture.

5. I want to use some screw-in compact fluorescent lamps in your model Rxx downlight. Is that possible?

Yes, however, there are two important points to keep in mind when planning to do this. First, will the lamp properly fit within the housing? Your screw-in CFL lamp may extend beyond the lip of the housing, which will cause an unpleasant look. Second, some trims are designed around specific lamp types. If you use a "cone" style trim that should have a reflector style lamp, if you use a "spiral" type CFL then much of the light output will not be distributed properly. Whenever you are considering using a screw-in CFL lamp in place of an incandescent in any downlight, it is best to check with the manufacturer for compatibility recommendations.

6. Can these fixtures be installed in a bathroom?

Yes, they are all suitable for damp locations (porch or bathroom) using any trim. Wet locations, above a shower or outdoors, require the use of specific trims. Consult your current WAC catalog or our website, www.waclighting.com, for our current offerings.

7. What downlight is the best choice for installation in an attic or other hot environment?

The WAC downlights are U.L. approved for most ceiling applications. For applications in unusually extreme conditions we recommend IC-Rated cans with PAR lamps. This combination will give you a housing and lamp that is the most durable and a low maintenance choice for this type of environment.

8. Please explain what you mean by Air-Tight downlight and why would I want to use one?

Any air-tight rated downlight has demonstrated in an independent testing laboratory environment that it will prevent air flow through the fixture. This is important because it saves money in heating and cooling costs. Just as important, some state regulations are now requiring that new home construction use this type of downlight.

9. Do any of the fixtures come with lamps?

No, our downlights use lamps that are readily available in all electrical supply centers.

10. The recessed lights I have in my bedroom are giving too much light. What can I do about it?

There are three simple solutions to your problem.

1. You may install a lower wattage lamp. With all incandescent downlights you can simply use the lowest wattage lamp available using the same base type.

2. You may use a coated specialty lamp. Most major lamp manufacturers are now making "color corrected" frosted incandescent lamps that provide a softer white light that does not seem as harsh as the light provided by a standard light frosted incandescent lamp.

3. You may install a dimmer to lower the light level. The additional benefit of this choice is it will extend your lamp life.

11. What is the difference between the remodel and new construction housings?

New construction housings are mounted to joists or T-Bar type ceiling grids. Remodel housings are used after a drywall ceiling is installed. A hole is made, the housing slips through and is mounted to the drywall panel with spring clips.

12. How do I choose between the different size downlights?

For aesthetic reasons you may want to choose the smallest aperture size, but consider the various lamp wattages available for the aperture size. For example a 4" fixture is limited to a 50watt maximum PAR lamp, which will be suitable for most 8' ceilings but not higher. Generally a 5" aperture will take up to 75 watts and a 6" up to 150watt lamps (subject to trim compatibility as listed in the catalog). A lamp performance chart in the back of the catalog will help your selection.

13. How many downlights should I use to light a room?

This is one of the most frequently asked questions, and one that does not have a standard answer.

The light level and coverage varies greatly with room usage. For general lighting applications a good rule of thumb is to space fixtures not more than half the ceiling height. For example if a room has an 8' ceiling you would not exceed 4' between fixtures. This ensures even coverage but may be far more than a den needs and less than a reading area or work station needs. Use this principle as a base line.

14. Do you have line voltage downlights that can be used in a sloped ceiling?

Yes, we have 6" trims and housings that can be used on a sloped ceiling.

LEDme™ DOWNLIGHTS – FREQUENTLY ASKED QUESTIONS

1. Are the LEDme™ Downlights UL listed?

Yes, all of our products are UL & CUL listed.

2. Are the LEDme™ Downlights dimmable?

Yes, we recommend particular dimmers for the LED Downlights.

2" LED Downlights: Lutron: SELV-600, DELV-600. Leviton: VPE04

3" & 4" LED Downlights: Lutron: DV-600P, S-600, D-600P Leviton: VPE-04,MLE-03

3. Can you use the LEDme™ Downlights in a damp location, like a bathroom, or a shower?

Yes, we have a shower trim available for our 3" (HR-LED331, HR-LED371) and 4" (HR-LED431, HR-LED471) LEDme™ Downlights.

4. Are there different trims for the 2" LEDme™ Downlights?

The trims for the 2" downlights are built in to the housings. The two parts (housing & trim) are integrated into one unit.

5. Are the LEDme™ Downlights available in multiple color temperatures?

Yes, our LEDme™ downlights can be purchased in warm (3000K) or cool (4500K) color temperatures, depending on your preference.

6. Are the LEDme™ Downlights IC rated?

Some of the LED Downlights are IC rated, please refer to specific model numbers to see which are, and are not, IC rated.

7. How long will the LEDme™ Downlights last?

The LED's in our LEDme™ Downlights have a rated life of 50,000 hours. As with all of our products, there is a five year warranty on the LEDme™ Downlights.

8. I have an existing downlight that I'd like to convert to LED, can I?

You will need to replace the housing and trim, but the 3" and 4" LEDme™ downlights will fit into existing 3" and 4" downlight spaces by purchasing the remodel housing for the LEDme™ downlights. The housings and trims are different.

9. What is the Invisible Trim™ option for the LEDme™ Downlights?

The Invisible Trim™ option allows the fixtures to be flush to the ceiling. You will still purchase a trim, however, it will sit flush with the ceiling, not rest below it.

Our Invisible Trim™ allows the fixture to be flush to the ceiling. The Invisible Trim™ comes with housing, however you can order separately if you need the Invisible Trim™

SURFACE MOUNT SPOTS – FREQUENTLY ASKED QUESTIONS

1. Are the Surface Mount fixtures U.L. listed?

Yes, they are U.L. & C.U.L. listed.

2. Please provide specifications for the surface mount fixtures.

See the table below. Transformers are available in an integral or remote type. We have fixtures that will use either magnetic or electronic transformers.

STYLE	LAMPS	VOLTAGE	TRANSFORMER	MAX WATT	NOTES
PAN-826	MR16	12V	Integral Electronic	50W	Mounts to standard fixture box.
PAN-101,102	GU10, MR16	120V	NA	50W	Uses line voltage/no transformer.
LP-007, 808*	MR16	12V	Integral Magnetic	50W	9' cord and plug installed when ordered with the "P" option
ME-007, 808*	MR16	12V	Integral Electronic	50W	4 ½" diameter canopy mounts over standard J-box.
ME-101,102	GU10, MR16	120V	NA	50W	Uses line voltage/ no transformer. 4 ½" diameter canopy mounts over standard J-box.
MI-1126, 1109***	MR11	12V	Remote transformer	35W	2 ½" diameter canopy (not for wall wiring). Available in black, white and brushed nickel
MM-204	MR11, MR16	12V	Remote transformer	50W	1" diameter canopy (not for wall wiring). Available in black, white and brushed nickel
MO-802, 826*	MR16	12V	Remote transformer	50W	4 ½" diameter canopy mounts over standard J-box.
MO-024, 048	A, G, R, Par	120V	NA	150W	4 ½" diameter canopy mounts over standard fixture box. Line volt flexible fixtures.
* = Base stock models, custom fixtures selection includes most styles offered as standard low voltage track heads.					
*** = MI (small canopy) fixtures can also be custom ordered with 50W MR16 low volt track head styles.					

3. What styles heads do you have for the LP, MI and ME units?

With the exception of our two line voltage models, most of our low voltage track heads can be custom adapted to any of these canopies. You can contact our WAC Lighting Specialist at 800.526.2588 for assistance in choosing a proper combination.

4. How do I order an LP, MI or ME with an 18" extension? What about with swivels?

These units can be extended 6", 12", 18", 24", 36" or 48". They are made to order items. When the unit is extended, we do not supply the 6' cord and plug. To order, specify the style number, followed by the length and color, i.e., LP-808/X18-BK. An example of an extension with a swivel is ME-007-X24S-BK. The ME line volt series can not be ordered with extensions.

5. Can an LP-808 fixture with an extension be mounted off a wall horizontally?

Yes, it can mounted off a wall horizontally.

6. Can these fixtures be installed in a damp location?

Yes, they are suitable for damp locations (porch or bathroom), but not a wet location (directly over a shower or outdoors).

7. Can I use 75W MR16 lamps with any of the low voltage Surface Mount fixtures?

No, the maximum rating for any of these units is 50W.

8. Can I order a PAN fixture with an extension?

No, the PAN fixtures cannot be extended.

9. What type of dimmer is required for use with an ME or PAN fixture?

Line voltage models use standard incandescent dimmers. Low voltage fixtures use an electronic low voltage transformer. It is recommended that these transformers be dimmed with an electronic low voltage dimmer.

10. What colors are available for the Surface Mount fixtures?

Most are available in a black and white painted finish. Some are also available in a brushed nickel and white with platinum plate finish

11. Can I order the low voltage PAN fixture in any track head style?

No, we don't offer customization of PAN fixtures, they are available in two standard styles – 826 and 866.

DISPLAY LIGHTS – FREQUENTLY ASKED QUESTIONS

1. Are the display lights U.L. or E.T.L. listed?

Yes, some are E.T.L. listed and some are U.L. listed. Check the product specification sheets for more information on the listing of any particular unit of interest.

2. Are your Display Lights low or line voltage? What type of lamps does each model use?

MODEL	LAMPS	MAX WATT	FINISH	VOLTAGE TYPE
DL-167	MR16G	50W	BK	Low voltage. Equipped with a 60W plug-in electronic transformer.
DL-007	MR16	50W	BK, WT	Low voltage. Equipped with a 60W plug-in electronic transformer.
DL-214	MR11G, MR16G	50W	BK, WT	Low voltage. Equipped with a 60W plug-in electronic transformer.
DL-024	A, G, R, PAR	150W	BK, WT	Line voltage.
DL-150	T-150-S (included)	150W	BK, WT	Line voltage.
DL-188	A, G, R, PAR	150W	BK, WT	Line voltage.
DL-701	A, PAR20, R20	60W	BK, WT	Line voltage.

3. What are the major differences between each model?

The styles that are available cover a variety of lamp types. For example, the DL-007 uses an MR16 and can accommodate the 008FP framing projector. The DL-150 is supplied with a 150W halogen lamp which will cover a larger wall or display area. The DL-024 uses a medium base incandescent socket and can cover many general lighting applications. In addition, the DL-024 will take a barn door attachment when used with par lamps.

4. How far do they extend?

The rod models periscope from 22" to 32".

5. What is the "standard clamp" that comes with the display lights?

The standard clamp works on flat surfaces ½" to 2½" wide.

6. What do I get when I order a WAC Lighting display light?

Besides the standard clamp, the fixtures come with a 10' cord and 3-prong (grounded) plug.

7. Can I get the display light with a 2-prong plug instead of a 3-prong plug?

No, they only come with a grounded (3-prong) plug.

8. Do you offer different clamps, other than the clamp supplied with the fixtures?

All display lights come with the standard clamp, you may purchase two optional clamps separately. The DLC-4 clamp is adjustable to accommodate flat surfaces from 2" to 4" wide, and the DLC-P pipe clamp works on pipes up to 2½" in diameter.

9. Where would you use such a display light?

They are ideal for use in lighting temporary exhibit booths, kiosk, craft displays, cubicle task lights and other applications where a portable and adjustable low profile source would be well suited.

LEDme™ SHOWCASE LIGHTS – FREQUENTLY ASKED QUESTIONS

1. Are the LEDme™ showcase lights height adjustable?

Yes, the LEDme™ showcase lights can be adjusted from 4" to 18", and they can also be field cut for a custom installation.

2. Are the LEDme™ showcase light lenses changeable?

Yes, you can easily change the beam angle lenses by unscrewing the head of the showcase light and replacing with another lens.

Lens Model Number	Beam
SL-LEN-S	8°
SL-LEN-F	25°
SL-LEN-W	40°

3. How many lights can I power with the LEDme™ showcase light driver?

You can run up to four showcase lights per 12W driver (LED-700MA12-P)

ELECTRONIC TRANSFORMERS – FREQUENTLY ASKED QUESTIONS

1. Please describe the features of your transformers.

FEATURE	ELECTRONIC	ELECTRONIC	ELECTRONIC
	EN-R Series	SST Series	EN-R2 Series
Input Voltage	120V	120V	120V
Output Voltage	12V	12V	12V
Wattage Available	Models up to 150W	60W, 150W	Models up to 300W
Dimmer Type	Electronic Low Voltage	Electronic Low Voltage	Electronic Low Voltage
Circuit Protection Features	Yes	Yes	Yes
Secondary Protection	Auto-reset	Auto-reset	Auto-reset
Thermal Protection	Yes	Yes	Yes
UL Class II Listed	No	No	Yes
Cycle	50-60Hz	50-60Hz	50-60Hz

2. What is the warranty of the transformers?

Our transformer warranty is 5 years.

3. Are WAC transformers U.L. listed?

Yes, there are two types of U.L. listings, component listed and standard listed. Components are identified by the backwards “UR” symbol. This means the transformer is part of a factory-installed fixture or to be used as a replacement. Remote transformers require the “UL” listing and are supplied in an approved enclosure.

4. What is a Class II transformer?

A Class II transformer is limited to no more than 60 watts. It is a low energy device and is considered “inherently limited and intrinsically safe” an integral fuse isolates primary and secondary circuits. Secondary wiring from a Class II transformer does not require conduit and clamp wiring techniques in accordance with Section 3 of the NEC. The HR-88 button lights and miniature recessed cabinet lights require this transformer.

5. 150 watts is not a lot of capacity, what if I need more?

Just use multiple transformers; there is not much cost differential between using multiple small wattage units and one larger unit. Multiple transformers can be wired to the same switch and will operate together (see diagram at the end of the section).

6. How long is the cord and plug that comes with the EN-1260-P-AR plug-in transformer? Can it be detached?

6 feet. Yes the cord can be detached to so the wire can negotiate smaller openings. The transformer has a built in on/off rocker switch.

7. Please provide specifications for the electronic transformers.

MODEL	INPUT VOLTS	MAX LOAD	MIN LOAD	INPUT CURRENT	OUTPUT VOLTAGE	CASE TEMP	AMBIENT TEMP
EN-1260-RB-AR EN-1260-R-AR	120V	60W	20W	0.5A	11.6V	90°C OR 194°F	-20°C TO +50°C OR -4°F TO 122°F
EN-1275-RB-AR EN-1275-R-AR	120V	75W	20W	0.6A	11.6V	90°C OR 194°F	-20°C TO +50°C OR -4°F TO 122°F
EN-1260-RB2 EN-1260-R2	120V	60W	20W	0.5A	11.6V	90°C OR 194°F	-20°C TO +50°C OR -4°F TO 122°F
EN-12100-RB-AR EN-12100-R-AR	120V	100W	60W	0.8A	11.6V	90°C OR 194°F	-20°C TO +50°C OR -4°F TO 122°F
EN-12150-RB-AR EN-12150-R-AR	120V	150W	60W	1.3A	11.6V	90°C OR 194°F	-20°C TO +50°C OR -4°F TO 122°F
EN-24150-RB-AR EN-24150-R-AR	120V	150W	60W	1.3A	23.6V	90°C OR 194°F	-20°C TO +50°C OR -4°F TO 122°F
EN-B12PY-AR	120V	250W	100W	2.A	11.5V	90°C OR 194°F	-20°C TO +50°C OR -4°F TO 122°F
EN-B24PZ-AR	120V	300W	100W	2.5A	23.6V	90°C OR 194°F	-20°C TO +50°C OR -4°F TO 122°F
EN-1260-P-AR	120V	60W	20W	0.5A	11.6V	75°C OR 167°F	-20°C TO +50°C OR -4°F TO 122°F
SST-60E	120V	60W	20W	0.5A	11.6V	90°C OR 194°F	-20°C TO +50°C OR -4°F TO 122°F
SST-150E	120V	150W	60W	1.25A	12V	90°C OR 194°F	-20°C TO +50°C OR -4°F TO 122°F

8. The chart above refers to minimum load. What does that mean?

The electronic transformers require a minimum load to operate. You need to stay within the specified minimum and maximum range for the transformer to operate properly.

9. How do I check the output voltage of your electronic transformers?

As our transformers operate at high frequency, the voltage cannot be read with most meters. A true RMS meter with 20KHZ capability is needed.

10. What percentage load can the transformers take?

You may load the transformer to its maximum capacity. For example, the EN-1260-RB-AR unit is rated for 60W you may utilize it to its maximum capacity of 60W. The same applies to all the other units.

11. In the model numbers of your EN series transformers, what does the “AR” signify?

The “AR” means auto reset. There are three main features:

- a. Short Circuit Protection: In the event of an electrical short, the transformer will stop functioning. After the shorted condition is removed and power is re-applied, the transformer will continue normal operation with no adverse effect to its life span.
- b. Thermal Overload Protection: The transformer will cease functioning in the event of a circuit overload condition. It will re-set once the condition is corrected.
- c. Soft start: Turning on a light switch applies a sudden surge of voltage to bulbs and transformers, shortening the life of both. The “soft start” feature applies the voltage gradually. You’ll notice a brief delay on a cold start and virtually no delay on a warm start.

12. I am concerned with a voltage drop in my application. Do you have any guidelines on the subject?

To minimize a voltage drop and lessened light output, the transformer should be located as close to the fixture as possible. A drop of 5% or less is generally acceptable. The chart below is a guideline to keep the drop below 5%.

MAXIMUM LENGTH / VOLTAGE DROP GUIDELINE					
WIRE SIZE	LOAD				
	35 W	50 W	60 W	100 W	150 W
18 GAUGE	8 FT	8 FT	6 FT	NA	NA
16 GAUGE	12 FT	12 FT	10 FT	NA	NA
14 GAUGE	21 FT	19 FT	17 FT	15FT	14FT
12 GAUGE	28 FT	25 FT	22 FT	20FT	18FT

13. Why do my fixtures flicker?

Check the distance of the last fixture to the transformer. Refer to the chart above for guidelines. The further the distance between the fixture and the transformer, the greater the voltage drop. This is one potential cause. Another possibility is that you are using a transformer that is too large and not meeting the minimum load requirement. Finally a loose connection may also cause flickering.

14. Why does a transformer/dimmer hum?

All dimmers create noise from the lamp, transformer or the dimmer itself. A loud buzz is a signal that the dimmer and transformer are not compatible. A mild low volume hum is normal. Whether the noise is objectionable depends on what you are dimming, how quiet the room is, how much sound the furniture and surfaces absorb, and how sensitive the customer is.

15. In a low voltage situation (12V) like a motor home or a boat, would I require a transformer for my fixtures?

Most RV’s and boats operate under 12V. Transformers are not necessary.

16. What does a multi terminal block (MTB-01) do?

It simplifies the wiring of multiple low voltage fixtures to a transformer. Instead of having a blob of wires to a wire-nut, it can be made much neater and allows better connections with an MTB-01. The MTB-01 can accommodate up to 6 fixtures only. The output (12V) wires connect to the input terminal of the MTB-01, marked “A”. Meanwhile, the wires from the 6 fixtures connect to the 6 output terminals of the MTB-01, marked “B” through “G”. Refer to installation instructions for wiring details.

17. Transformer Wiring Diagram

Single Transformer

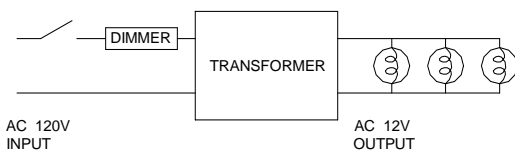

Multiple Transformers

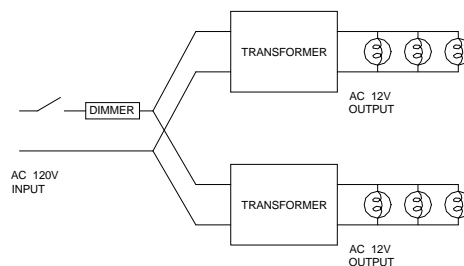

MAGNETIC TRANSFORMERS – FREQUENTLY ASKED QUESTIONS

- 1. Are your WAC Remote Magnetic Transformers UL listed?**
Yes, they are U.L. and C.U.L. listed.
- 2. Why would I want to use a Remote Magnetic Transformer?**
Magnetic transformers have a proven core & coil design. They are the most durable and reliable low voltage lighting transformers where high heat is a factor.
- 3. What is the difference between an electronic and magnetic transformer?**
Magnetic transformers are larger and have greater capacities. Electronic transformers provide value in a smaller package.
- 4. Can I order an old style SRT-600M-12V/24V to match my existing transformers?**
No, the current WAC with dedicated 12V or 24V output is the only ones we will be offering.
- 5. Do I need a de-buzzing coil for these transformers?**
No, they are already supplied with a built-in de-buzzing coil (LM-DBC12XXXXX). In especially sensitive applications you can order an additional de-buzzing coil, however in most cases you will find it to be unnecessary.
- 6. What kind of dimmer can I use with the Magnetic Transformers?**
A magnetic low voltage dimmer.
- 7. Where is the best place to mount a Remote Magnetic Transformer?**
In a cool dry place where you can gain service access. The design of these transformers allows you to mount these in between your 2x6 wall joists where the transformer could then be accessed by a wall panel.
- 8. What kind of warranty is available with these transformers?**
These transformers carry a 5 year product replacement warranty.
- 9. What percentage of the rated load can these transformers really take?**
100%. No de-rating is required, but be sure secondary wires are rated for the amperage: For example a 300W 12 Volt transformer is 25 AMPS and requires 10 gauge secondary wires.
- 10. I am concerned with a voltage drop in my application. Do you have any guidelines on the subject?**
The amount of voltage drop you will experience with your transformer is a combination of both the wire gauge and total load on the system (wattage). Increasing the wire gauge will allow you to increase the overall system distance.

CFL Lamps – FREQUENTLY ASKED QUESTIONS

1. Are our CFL lamps U.L. listed?

Our CFL PAR lamp (E26) and GU24 lamp are U.L. and C.U.L. listed.

2. Are our CFL lamps Energy star rated?

Our CFL GU24 lamp is Energy star rated product.

3. What is the voltage our CFL lamps work on?

For our CFL PAR (E26) lamp and GU24 lamp, they are self-ballast and are able to work on 120V. For other CFL lamps, it depends on different ballasts that the customer is using with. Please check with the ballast manufacturer or instructions listed on the ballast.

4. Is our CFL lamp self-ballast?

For our CFL PAR (E26) lamp and GU24 lamp, it is self-ballast and is able to work on 120V. For other CFL models, it depends on different ballasts that customer is using with. For other CFL lamps, it depends on different ballasts that the customer is using with. Please check with the ballast manufacturer or instructions listed on the ballast.

5. Is our CFL lamp dimmable?

For our CFL GU24 lamp, it is dimmable using a regular incandescent dimmer. For our CFL PAR (E26) lamp, it is not dimmable. For other CFL lamps, it depends on different dimmable ballasts that the customer is using with. Please check with the ballast manufacturer.

6. What is the CFL GU24 adaptor (CF-GU24-ADP) used for?

It is used for converting a socket set that is E26 base to GU24 base. Please keep in mind that the adaptor has a lock-in device, once it is attached to an E26 base, it cannot be taken out.

7. When purchasing the CFL GU24 lamp, does it come with the GU24 adaptor?

Yes, adaptor will come with the purchase of GU24 lamp.

8. What is the color temperature of our CFL lamp?

For our CFL PAR (E26) and GU24 lamps, the color temperature is 2700K. For our CFL PLC, PLT, PLL and T5 lamp, the color temperature comes in 2700K and 4100K.

9. What is the life expectancy of the CFL lamp?

Our CFL lamps have an average life span of 10,000 hours, which is 5 times the life of a regular incandescent lamp.



WAC LIGHTING

Responsible Lighting

GARDEN CITY, NY

LOS ANGELES, CA

E-MAIL: sales@wacighting.com

WEBSITE: www.wacighting.com

WAC IS A U.L. AND E.T.L. LISTED COMPANY