

The high power LED 5x2Watt PAR20 can be the replacement of 50Watt traditional PAR20 Spot light source based **E27, E26.** high performance, energy saving, and long lasting.



\$128.50 + S & H weight 1lbs.

## Features

- \* Light source: **5pc x 2wat** (High power Cree LEDs)<sup>®</sup>
- \* Life time: more than 50,000 hours
- \* Max Lumious flux output: 520lm
- \* Light output equal to 50Watt traditional PAR20 light
- \* More energy-efficient: 80lm/ Watt
- \* Excellent heat Aluminum sink and stable circuit design
- \* No UV, No IR radiation, No mercury or other inorganics
- \* Safety standard: **CE** and **RoHs** pending
- \* Work voltage: AC100-240V
- \* Protection degree: IP54



## Applications:

- \* Landscape accent/ spot lighting
- \* Architectural Lighting
- \* Artwork lighting, Display case accent
- \* Mood lighting
- \* Hotel, cafe or other Gerenal lighting

**Product Speciation:**

- \* **Wattage:** 9±10%W
- \* **Beam angle:** 15 or 20 °
- \* **Base holder:** E27, E26.
- \* **Surface temperature:** ≤65 °C
- \* **Diameter:** φ75mmmm
- \* **Weight:** 0.090-0.092kg
- \* **Rendering index(Ra):**
  - > 80 warm white
  - > 70 cool white
- \* **Material:** Aluminum housing with PC or glass cover
- \* **Work environment and storage temperature:** -20° to +40°

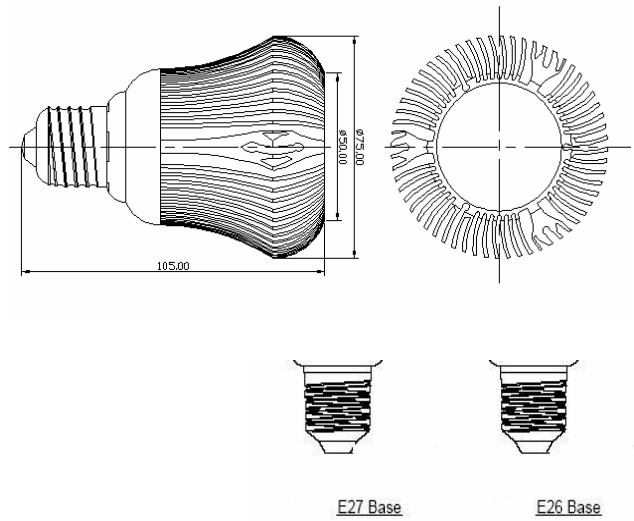

Model	Color	Color temperature (K) or wavelength (nm)	Work Voltage	Power (Wattage)	Luminous flux (lm)	Beam angle (°)
iL-PAR20W5A4	cool white	6000-7000K	AC100-240V	5x2Watt	500±20%	90-110°
iL-PAR20WW5A4	warm white	2500-3500K		5x2Watt	400±20%	90-110°
iL-PAR20R5A4	red	625nm		/		
iL-PAR20Y5A4	yellow	595nm		/		
iL-PAR20G5A4	green	520-525nm		/		
iL-PAR20B5A4	blue	470-475nm		/		

## Illumination Characteristics (Tc= 25 °C)

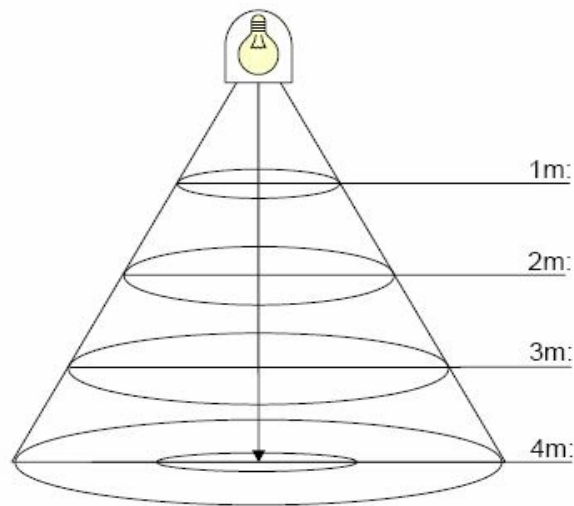

Distance (cm)	Typical illumination measured (Lux)		
	cool white	natural white	warm white
30	≥3100Lux	/	≥1800 Lux
50	≥2400 Lux	/	≥870Lux
100	≥900 Lux	/	≥450 Lux
200	≥400Lux	/	≥110 Lux

---

## Packing specification:

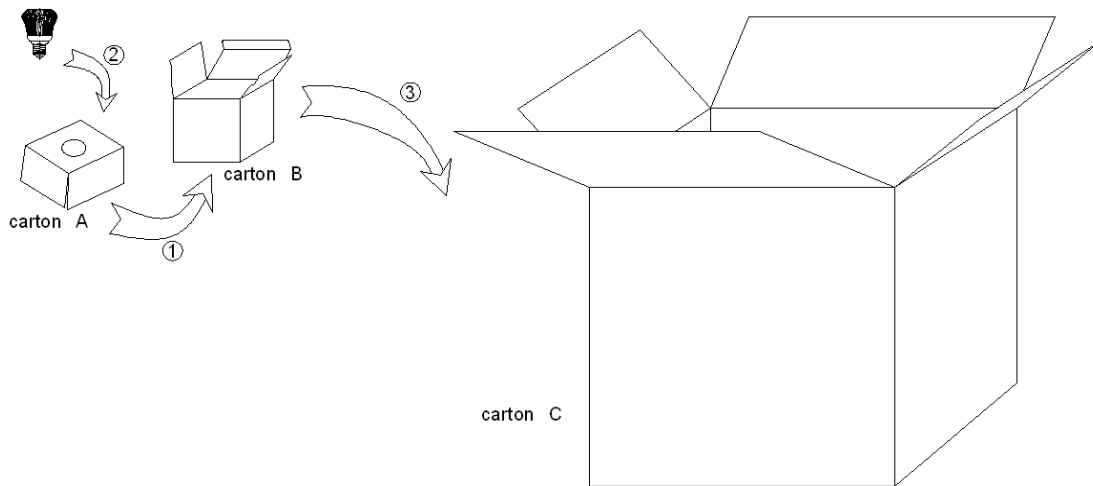

**Carton size: 300x240x500mm**

**Qty/Ctn: 30pcs/Ctn**

**Gross weight: 8.8kg/ctn**

\* **Also can make and printing boxes according to customer's requirement.**

## Warranty:

※ **Manufacturer warrants to the purchaser that each product manufactured and sold by it will be free defects in material and workmanship in its intended use (normal wear and tear excepted) for the period of **One** year from purchase date (invoice date) from seller.**

**Quality guarantee is based on storing, installing, and operating correctly in the normal operation condition.**

**All products are warranted for **One** year from the date of purchase.**

**A copy of the invoice is required for warranty repairs or replacements.**

**The purchaser is responsible for the return shipping and shipping cost.**

Specification are subjected to change without notice.

---